

**MacDon™**

**R80 Pull-Type  
Rotary Disc Mower Conditioner  
Unloading & Assembly Instructions**



**R80 PULL-TYPE ROTARY DISC MOWER CONDITIONER**

# INTRODUCTION

This instruction describes the unloading, set-up and pre-delivery requirements for the Model R80 Pull-Type Rotary Disc Mower Conditioner. Use the table of contents to guide you to specific areas.

CAREFULLY READ ALL THE MATERIAL PROVIDED BEFORE ATTEMPTING TO UNLOAD, ASSEMBLE, OR USE THE MACHINE.

## TABLE OF CONTENTS

INTRODUCTION.....	1
GENERAL SAFETY.....	2
RECOMMENDED TORQUES.....	4
A.    GENERAL.....	4
B.    SAE BOLTS.....	4
C.    METRIC BOLTS.....	4
D.    HYDRAULIC FITTINGS.....	5
CONVERSION CHART.....	6
ACCRONYMS AND ABBREVIATIONS.....	7
STEP 1. UNLOAD ARTICULATING POWER TONGUE (APT).....	8
STEP 2. UNLOAD HEADER.....	9
STEP 3. INSTALL GAUGE ROLLERS OR ADJUSTABLE SHOES – 16 FT ONLY.....	10
STEP 4. LOWER MOWER CONDITIONER.....	12
STEP 5. REMOVE SHIPPING CHANNELS AND BLOCKING.....	13
STEP 6. REMOVE FORMING SHIELD.....	14
STEP 7. UNPACK APT.....	15
STEP 8. ATTACH APT.....	17
STEP 9. CONNECT LIFT HOSE.....	18
STEP 10. CONNECT WIRING HARNESS.....	18
STEP 11. INSTALL HYDRAULIC MOTOR.....	19
STEP 12. INSTALL WHEELS.....	20
STEP 13. INSTALL CENTER LINK.....	21
A.    MECHANICAL LINK.....	21
B.    HYDRAULIC LINK.....	21
STEP 14. REMOVE BANDING AT LIFT CYLINDERS.....	21
STEP 15. ATTACH MOWER CONDITIONER TO TRACTOR.....	22
A.    DRAWBAR TYPE HITCH.....	22
B.    3-POINT HITCH (Cat. II, III, or IIIN).....	25
STEP 16. ATTACH HYDRAULICS AND ELECTRICAL.....	28
STEP 17. INSTALL STEERING CYLINDER.....	29
STEP 18. FILL LIFT CYLINDERS.....	30
STEP 19. INSTALL FLOAT SPRINGS.....	31
STEP 20. INSTALL FORMING SHIELD.....	32
A.    INSTALL SUPPORTS.....	32
B.    INSTALL FORMING SHIELD.....	32
STEP 21. INSTALL TALL CROP FEED PLATES.....	34
STEP 22. INSTALL OPTIONS.....	36
A.    TALL CROP DIVIDER KIT.....	36
B.    SHOE LIFT KIT.....	36
STEP 23. LUBRICATE THE MOWER CONDITIONER.....	37
STEP 24. PERFORM PRE-DELIVERY CHECKS.....	42
A.    DRIVE BELTS.....	42
B.    CONDITIONER ROLLS.....	44
C.    LIGHTS.....	45
D.    MANUALS.....	45
E.    RUN-UP THE MOWER CONDITIONER.....	46

# GENERAL SAFETY



## CAUTION

The following are general farm safety precautions that should be part of your operating procedure for all types of machinery.

- Protect yourself.

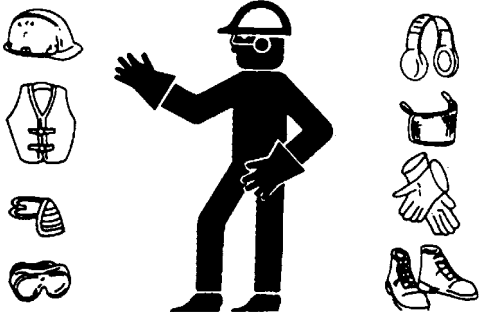

- When assembling, operating and servicing machinery, wear all the protective clothing and personal safety devices that COULD be necessary for the job at hand. Don't take chances.

- You may need:
  - a hard hat.
  - protective shoes with slip resistant soles.
  - protective glasses or goggles.
  - heavy gloves.
  - wet weather gear.
  - respirator or filter mask.
  - hearing protection. Be aware that prolonged exposure to loud noise can cause impairment or loss of hearing. Wearing a suitable hearing protective device such as ear muffs (A) or ear plugs (B) protects against objectionable or loud noises.

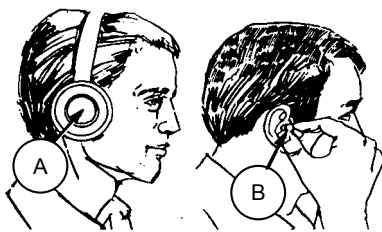

- Provide a first-aid kit for use in case of emergencies.



- Keep a fire extinguisher on the machine. Be sure the extinguisher is properly maintained and be familiar with its proper use.
- Keep young children away from machinery at all times.
- Be aware that accidents often happen when the operator is tired or in a hurry to get finished. Take the time to consider the safest way. Never ignore warning signs of fatigue.
- Wear close-fitting clothing and cover long hair. Never wear dangling items such as scarves or bracelets.
- Keep hands, feet, clothing and hair away from moving parts. Never attempt to clear obstructions or objects from a machine while the engine is running.

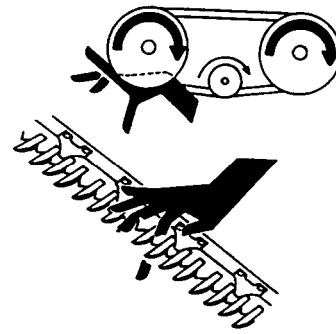

- Keep all shields in place. Never alter or remove safety equipment. Make sure driveline guards can rotate independently of the shaft and can telescope freely.
- Use only service and repair parts made or approved by the equipment manufacturer. Substituted parts may not meet strength, design, or safety requirements.
- Do not modify the machine. Unauthorized modifications may impair the function and/or safety and affect machine life.

*(continued next page)*

- **Stop engine and remove key from ignition before leaving operator's seat for any reason. A child or even a pet could engage an idling machine.**
- **Keep the area used for servicing machinery clean and dry. Wet or oily floors are slippery. Wet spots can be dangerous when working with electrical equipment. Be sure all electrical outlets and tools are properly grounded.**
- **Use adequate light for the job at hand.**
- **Keep machinery clean. Do not allow oil or grease to accumulate on service platforms, ladders or controls. Clean machines before storage.**
- **Never use gasoline, naphtha or any volatile material for cleaning purposes. These materials may be toxic and/or flammable.**
- **When storing machinery, cover sharp or extending components to prevent injury from accidental contact.**



# RECOMMENDED TORQUES

## A. GENERAL

- Tighten all bolts to the torques specified in chart unless otherwise noted throughout this manual.
- Check tightness of bolts periodically, using bolt torque chart as a guide.
- Replace hardware with the same strength bolt.
- Torque figures are valid for non-greased or non-oiled threads and heads unless otherwise specified. Do not grease or oil bolts or capscrews unless specified in this manual. When using locking elements, increase torque values by 5%.

## B. SAE BOLTS

BOLT DIA. "A" in.	NC BOLT TORQUE*			
	SAE 5		SAE 8	
	lbf-ft	N-m	lbf-ft	N-m
1/4	9	12	11	15
5/16	18	24	25	34
3/8	32	43	41	56
7/16	50	68	70	95
1/2	75	102	105	142
9/16	110	149	149	202
5/8	150	203	200	271
3/4	265	359	365	495
7/8	420	569	600	813
1	640	867	890	1205

\* Torque categories for bolts and capscrews are identified by their head markings.

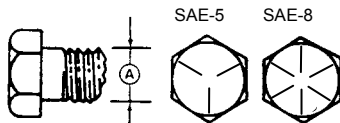

## C. METRIC BOLTS

BOLT DIA. "A"	NC BOLT TORQUE*			
	8.8		10.9	
	lbf-ft	N-m	lbf-ft	N-m
M3	0.4	0.5	1.3	1.8
M4	2.2	3	3.3	4.5
M5	4	6	7	9
M6	7	10	11	15
M8	18	25	26	35
M10	37	50	52	70
M12	66	90	92	125
M14	103	140	148	200
M16	166	225	229	310
M20	321	435	450	610
M24	553	750	774	1050
M30	1103	1495	1550	2100
M36	1917	2600	2710	3675

\* Torque categories for bolts and capscrews are identified by their head markings.

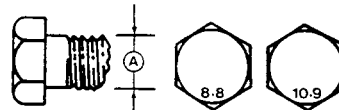

## D. HYDRAULIC FITTINGS

### FLARE TYPE

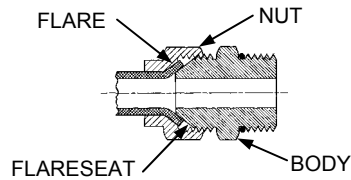

- Check flare and flare seat for defects that might cause leakage.
- Align tube with fitting before tightening.
- Lubricate connection and hand tighten swivel nut until snug.
- To prevent twisting the tube(s), use two wrenches. Place one wrench on the connector body and with the second tighten the swivel nut to the torque shown.

TUBE SIZE O.D. (in.)	NUT SIZE ACROSS FLATS (in.)	TORQUE VALUE*		RECOMMENDED TURNS TO TIGHTEN (AFTER FINGER TIGHTENING)	
		lbf-ft	N-m	Flats	Turns
3/16	7/16	6	8	1	1/6
1/4	9/16	9	12	1	1/6
5/16	5/8	12	16	1	1/6
3/8	11/16	18	24	1	1/6
1/2	7/8	34	46	1	1/6
5/8	1	46	62	1	1/6
3/4	1-1/4	75	102	3/4	1/8
7/8	1-3/8	90	122	3/4	1/8

\* The torque values shown are based on lubricated connections as in reassembly.

### O-RING TYPE

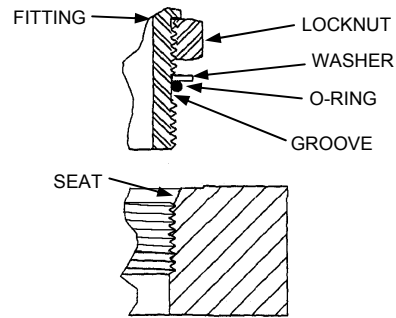

- Inspect O-ring and seat for dirt or obvious defects.

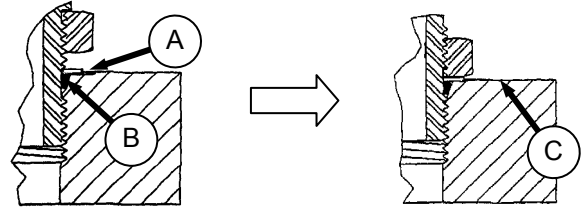

- On angle fittings, back off the lock nut until washer (A) bottoms out at top of groove (B) in fitting.
- Hand tighten fitting until back up washer (A) or washer face (if straight fitting) bottoms on part face (C) and O-ring is seated.
- Position angle fittings by unscrewing no more than one turn.
- Tighten straight fittings to torque shown.
- Tighten angle fittings to torque shown in the following table while holding body of fitting with a wrench.

THD SIZE (in.)	NUT SIZE ACROSS FLATS (in.)	TORQUE VALUE*		RECOMMENDED TURNS TO TIGHTEN (AFTER FINGER TIGHTENING)	
		lbf-ft	N-m	Flats	Turns
3/8	1/2	6	8	2	1/3
7/16	9/16	9	12	2	1/3
1/2	5/8	12	16	2	1/3
9/16	11/16	18	24	2	1/3
3/4	7/8	34	46	2	1/3
7/8	1	46	62	1-1/2	1/4
1-1/16	1-1/4	75	102	1	1/6
1-3/16	1-3/8	90	122	1	1/6
1-5/16	1-1/2	105	142	3/4	1/8
1-5/8	1-7/8	140	190	3/4	1/8
1-7/8	2-1/8	160	217	1/2	1/12

\* The torque values shown are based on lubricated connections as in reassembly.

# CONVERSION CHART

QUANTITY	INCH-POUND UNITS		FACTOR	SI UNITS (METRIC)	
	UNIT NAME	ABBR.		UNIT NAME	ABBR.
Area	acres	acres	$\times 0.4047 =$	hectares	ha
Flow	US gallons per minute	(gpm)	$\times 3.7854 =$	liters per min	L/min
Force	pounds force	lbf	$\times 4.4482 =$	Newtons	N
Length	inch	in.	$\times 25.4 =$	millimeters	mm
	foot	ft	$\times 0.305 =$	meters	m
Power	horsepower	hp	$\times 0.7457 =$	kilowatts	kW
Pressure	pounds per square inch	psi	$\times 6.8948 =$	kilopascals	kPa
			$\times .00689 =$	megapascals	MPa
Torque	pound feet or foot pounds	lbf-ft or ft-lbf	$\times 1.3558 =$	newton meters	N·m
	pound inches or inch pounds	lbf-in. or in-lbf	$\times 0.1129 =$	newton meters	N·m
Temperature	degrees Fahrenheit	°F	$(F - 32) \times 0.56 =$	Celsius	°C
Velocity	feet per minute	ft/min	$\times 0.3048 =$	meters per min	m/min
	feet per second	ft/s	$\times 0.3048 =$	meters per sec	m/s
	miles per hour	mph	$\times 1.6063 =$	kilometers per hour	km/h
Volume	US gallons	US gal.	$\times 3.7854 =$	liters	L
	ounces	oz.	$\times 29.5735 =$	milliliters	ml
	cubic inches	in. <sup>3</sup>	$\times 16.3871 =$	cubic centimeters	cm <sup>3</sup> or cc
Weight	pounds	lb	$\times 0.4536 =$	kilograms	kg

## UNLOADING AND ASSEMBLY

### ACCRONYMS AND ABBREVIATIONS

TERM	DEFINITION
API	American Petroleum Institute
APT	Articulating Power Tongue
ASTM	American Society Of Testing And Materials
C	Celsius
F	Fahrenheit
ft/min	feet per minute
ft/s	feet per second
gpm	U.S. gallons per minute
hp	horsepower
in. <sup>3</sup>	cubic inches
kPa	kilopascals
lbf	pounds force
lbf·ft or ft·lbf	pound feet or foot pounds
lbf·in or in·lbf	pound inches or inch pounds
mPa	megapascals
mph	miles per hour
N	newtons
N·m	newton meters
oz.	ounces
psi	pounds per square inch
PTO	Power Take-Off
rpm	Revolutions Per Minute
SAE	Society Of Automotive Engineers

## UNLOADING AND ASSEMBLY

### STEP 1. UNLOAD ARTICULATING POWER TONGUE (APT)



#### CAUTION

To avoid injury to bystanders from being struck by machinery, do not allow persons to stand in unloading area.



#### CAUTION

Equipment used for unloading must meet or exceed the requirements specified below. Using inadequate equipment may result in chain breakage, vehicle tipping or machine damage.

<i>LIFTING VEHICLE</i>	
Min. Lifting Capacity	8000 lb. (3630 kg)
Min. Lifting Height	15 ft. (4.5 m)

<i>CHAIN</i>	
Overhead Lifting Quality (1/2 inch)	5000 lb. (2270 kg) Min. Working Load

- a. Remove hauler's tie down straps and chains.



- b. Attach chain to two brackets on top of APT as shown.
- c. Adjust chain lengths so APT is lifted evenly.
- d. Raise APT off deck, back up until unit clears trailer and slowly lower to 6 inches (150 mm) from ground.

#### IMPORTANT

Take care not to contact the other machine if load is two-wide.

- e. Take to storage or set-up area and set APT down securely on level ground.
- f. Repeat for second APT if required.
- g. Check for shipping damage and missing parts.

## UNLOADING AND ASSEMBLY

### STEP 2. UNLOAD HEADER



#### CAUTION

To avoid injury to bystanders from being struck by machinery, do not allow persons to stand in unloading area.



#### CAUTION

Equipment used for unloading must meet or exceed the requirements specified below. Using inadequate equipment may result in chain breakage, vehicle tipping or machine damage.

LIFTING VEHICLE	
Min. Lifting Capacity	8000 lb. (3630 kg)
Min. Lifting Height	15 ft. (4.5 m)

CHAIN	
Overhead Lifting Quality (1/2 inch)	5000 lb. (2270 kg) Min. Working Load



#### WARNING

Be sure forks are secure before moving away from load. Stand clear when lifting.

- Remove hauler's tie down straps and chains.



- Approach mower-conditioner from either its "underside" or "topside" and slide forks in underneath lifting framework as far as possible.

#### NOTE

When possible, approach from the underside to minimize potential for scratching the unit.

- Raise mower-conditioner off deck.

#### IMPORTANT

Take care not to contact the other machine if load is two-wide.

- Back up until unit clears trailer and slowly lower to 6 inches (150 mm) from ground.
- Take to storage or set-up area set machine down securely on level ground.
- Repeat for other mower conditioner if required.
- Check for shipping damage and missing parts.

## UNLOADING AND ASSEMBLY

### STEP 3. INSTALL GAUGE ROLLERS OR ADJUSTABLE SHOES – 16 FT ONLY

If kits are not supplied, proceed to STEP 4, LOWER MOWER CONDITIONER, otherwise proceed as follows:

#### NOTE

*These kits may be installed later in the header assembly sequence but it may be easier prior to laying the header down.*

#### I. GAUGE ROLLERS

- a. Unpack gauge roller bundle.

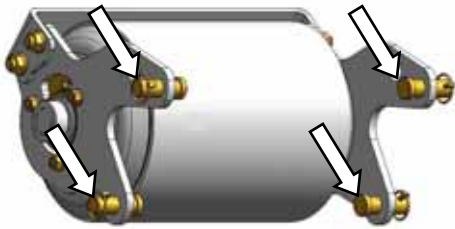

- b. Remove four clevis pins from roller assembly.

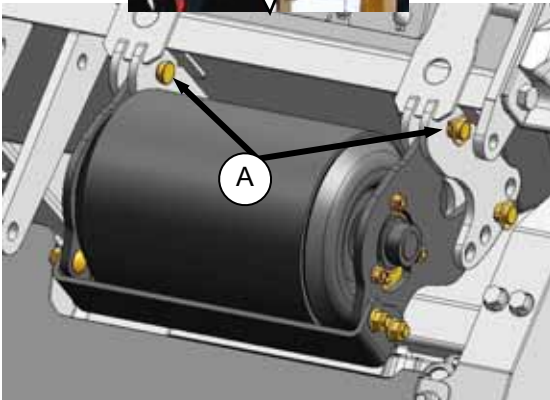

- c. Position gauge roller assembly on frame and secure with two clevis pins (A). Secure pins with lynch pins.

#### NOTE

*It may be necessary to make the following adjustment to the roller assembly if there is interference with the header frame:*

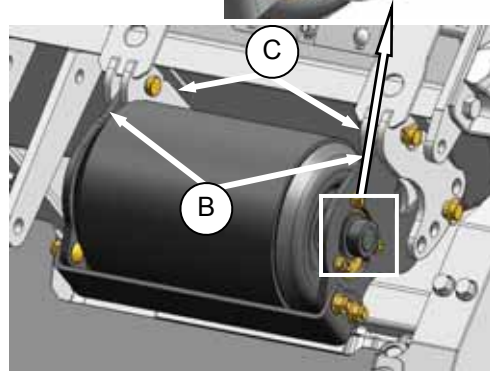
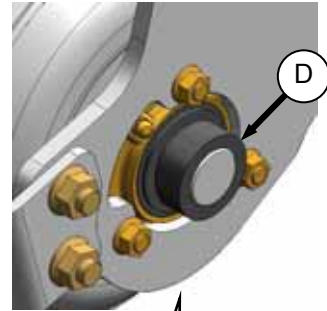

1. Determine the amount of interference between the roller assembly flanges (B) and the frame brackets (C).
2. Unlock the locking collar (D) on each bearing.
3. Adjust the flanges (B) to accommodate the interference.
4. Re-lock the bearings.
5. Install the roller assembly.

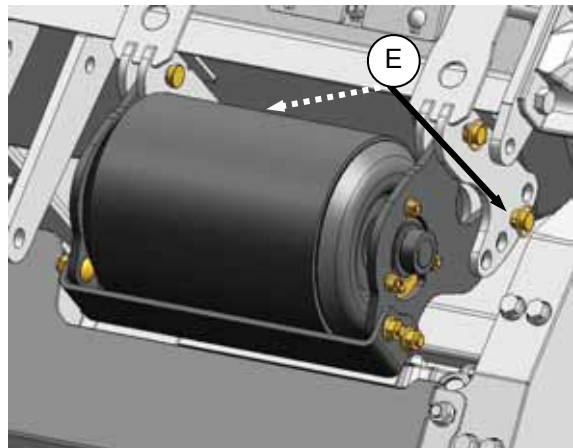

- d. Adjust roller assembly to desired height and install two clevis pins (E). Secure with lynch pins.
- e. Repeat above steps for opposite side. Set both gauge rollers to same position.

## UNLOADING AND ASSEMBLY

### II. SKID SHOES

- a. Unpack skid shoe bundle.

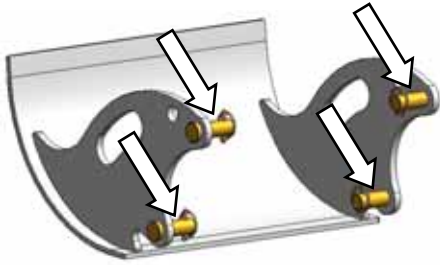

- b. Remove four clevis pins from skid shoe.
- c. Position skid shoe on frame and secure with two clevis pins (C). Secure pins with lynch pins.

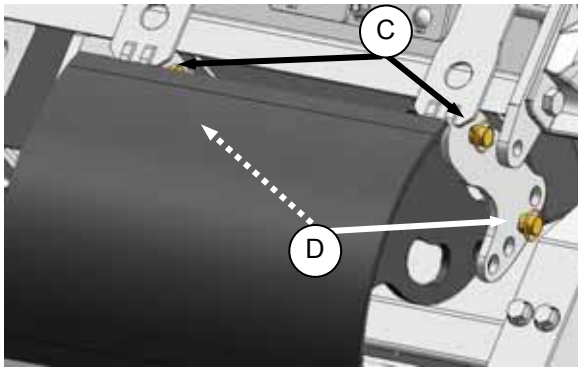

- d. Adjust skid shoe to desired height and install two clevis pins (D). Secure with lynch pins.
- e. Repeat above steps for opposite side. Set both skid shoes to same position.

## UNLOADING AND ASSEMBLY

### STEP 4. LOWER MOWER CONDITIONER

- a. Attach either a spreader bar or chain to forks.



#### CAUTION

Ensure spreader bar or chain is secured to the forks so that it cannot slide off the forks or towards the mast as the header is lowered to the ground.

Chain Type	Overhead Lifting Quality (1/2 Inch)
Min. Working Load	5000 lb. (2270 kg)

- b. Drive lifting vehicle to approach header from its "underside".



- c. Attach chain hooks to hooks on either side of header.



#### CAUTION

Stand clear when lowering the header.

#### NOTE

*Do not lift at hooks when unloading from trailer. This procedure is only for laying the machine over into working position.*

#### IMPORTANT

Chain length must be sufficient to provide a minimum 4 feet (1.2 m) vertical chain height.

- d. Raise forks until lift chains are fully tensioned.

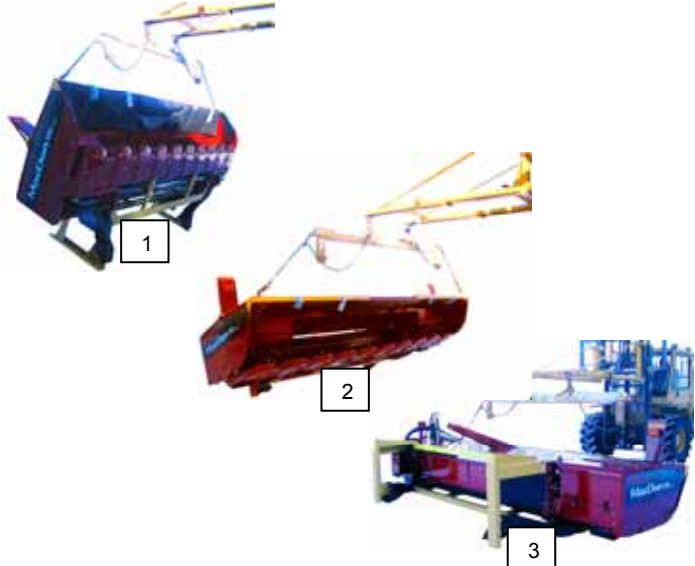

- e. Back up SLOWLY while simultaneously lowering machine until cutterbar rests on ground.  
f. Remove chain from header.

MAST PERPENDICULAR TO GROUND

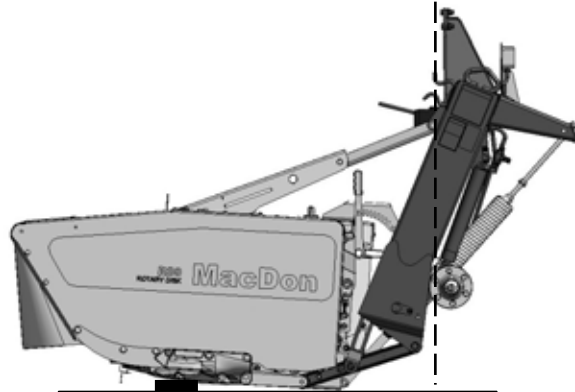

ADJUST HEIGHT AS REQUIRED

#### NOTE

*The front face of the carrier mast should be approximately vertical for easier assembly of the APT.*

- g. Remove chain from header.

## UNLOADING AND ASSEMBLY

### STEP 5. REMOVE SHIPPING CHANNELS AND BLOCKING

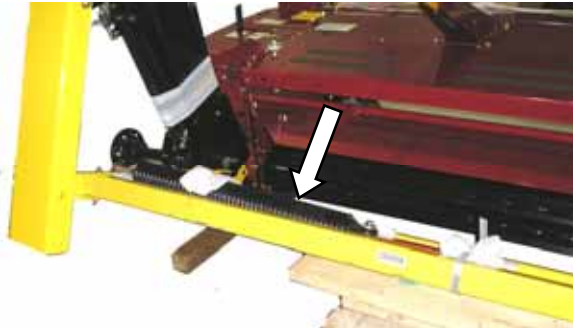

- a. Cut the banding on the shipping beam at the rear of carrier frame and remove components from inside the shipping beam.

#### NOTE

*Hardware bag is for STEP 20. INSTALL FORMING SHIELD.*

- b. Place LH spring assembly (heavy) near LH side of carrier. Place RH spring assembly (light) near RH side of carrier.

#### NOTE

*The following steps remove the stand as an assembly. These components may also be removed individually.*



- c. Place blocks under the shipping beam at the rear of the carrier frame.



- d. Loosen the shipping stand bolt at the lower end of each carrier frame leg.



- e. Remove the bolt that secures shipping stand at each float spring anchor.  
f. Remove the support blocks and lower the shipping stand to the ground.



- g. Remove bolts at carrier frame legs and remove shipping stand frame.



- h. Cut banding that secures angles to carrier frame tube and remove angles.

## UNLOADING AND ASSEMBLY

### STEP 6. REMOVE FORMING SHIELD

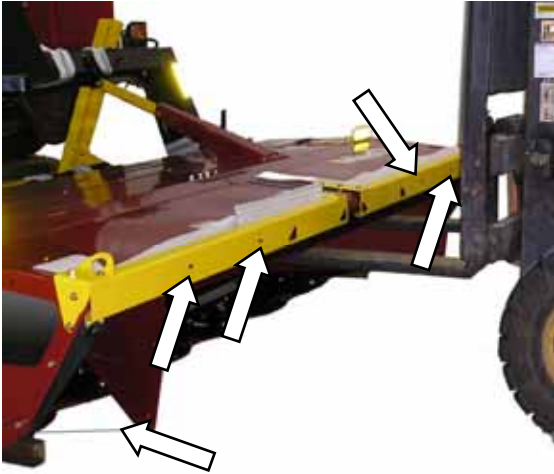

- Position lift forks with extensions under forming shield at front of header.
- Cut shipping wire and remove four bolts at front edge of forming shield.



- Cut shipping wire (2 places) on aft end of forming shield at rear of header.



- Manually slide forming shield onto lift forks.

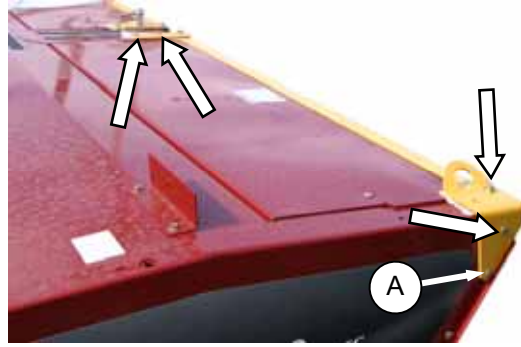

- Remove five bolts and nuts on each door and remove front angles and lift hooks. Retain lower side bolt (A) for re-installation at same location after hook is removed.



### WARNING

Ensure cutterbar is completely clear of foreign objects. These objects can be ejected with considerable force when the machine is started and may result in serious injury or machine damage.

- Thoroughly check cutterbar area for wooden blocking, banding, and hardware that may have fallen between discs.



- Cut plastic ties at end curtains and remove creases in curtains.



- Ensure that curtains hang properly and completely enclose cutterbar area. Minor creases in curtains will eventually straighten out.

## UNLOADING AND ASSEMBLY

### STEP 7. UNPACK APT



- a. Attach chain from lifting vehicle or hoist to APT hooks, and raise it approximately 24 inches (610 mm) off ground.



- b. Cut banding securing hydraulic motor and hoses to underside of APT.



### CAUTION

Hold motor to keep it from dropping to the ground when cutting band around motor.



- c. Route motor and hoses to the left side of the APT.



- d. Secure the motor to the steering cylinder with shipping wire.



- e. Remove the two bolts securing wooden stand to APT pin.

### NOTE

*Bolt and washer at top of pin keeps pin in APT when bolts are removed.*

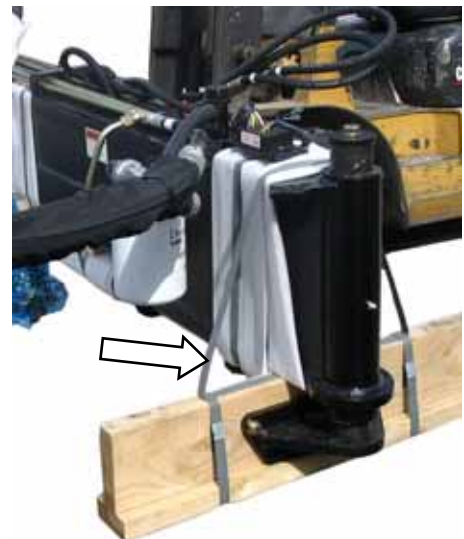

- f. Cut banding securing wooden stand to APT and remove wooden stand.

*(continued next page)*

## UNLOADING AND ASSEMBLY



- g. Remove bolt and washer securing pin to APT.



### CAUTION

Hold pin from falling to the ground when bolt is removed.



- h. Remove pin and reinsert pin in APT from top.

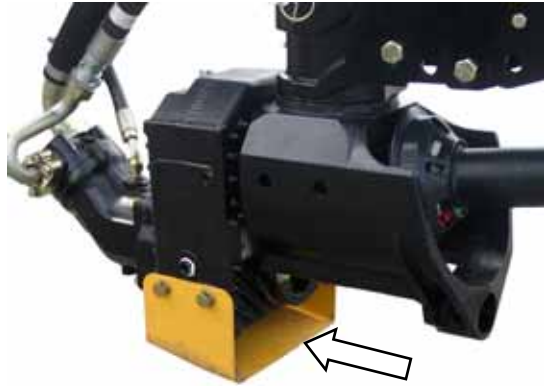

- i. Remove four bolts securing shipping bracket at front of APT, and remove bracket.  
j. Remove banding from jack.

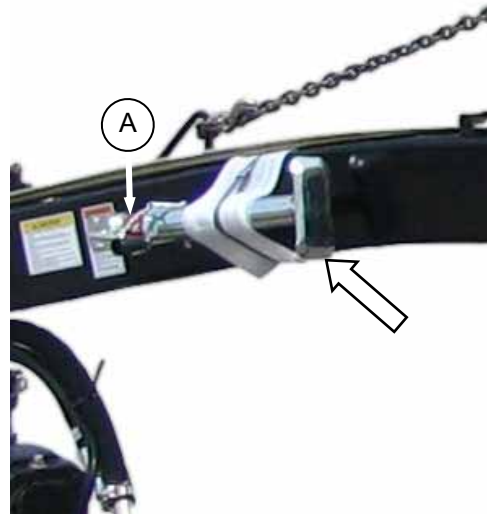

- k. Remove pin (A) securing jack to APT and remove jack from shipping position.



- l. Install at jack location at front of APT and secure with pin (A).

## UNLOADING AND ASSEMBLY

### STEP 8. ATTACH APT



#### CAUTION

Keep hands clear when lowering APT.



- a. Remove the six bolts and nuts from frame and retain for reinstallation.



- b. Using a forklift or equivalent, manoeuvre APT into position and install pivot pin (A) into mower-conditioner frame.

#### NOTE

Use the jack to adjust the pitch of the APT for proper alignment when installing pivot pin.

#### NOTE

Pin may need to be tapped into final position with a hammer due to the tight clearances.

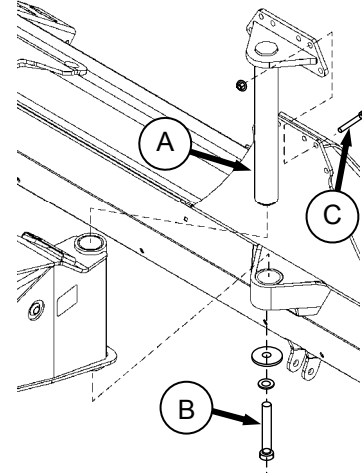

- c. Secure pivot pin (A) to frame by installing six 5/8 x 1.75 long Gr. 8 bolts (C) with lock nuts removed at step a. Install bolts with heads facing aft.
- d. Torque to 250 ft-lbf (339 N·m).
- e. Install bolt (B), lockwasher, and flatwasher removed at STEP 7g. at lower end of pivot pin and tighten bolt.
- f. Position APT with jack so that rear span of APT is approximately horizontal. Remove lifting chain from APT.

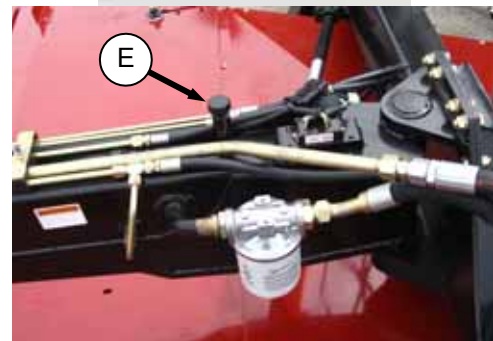
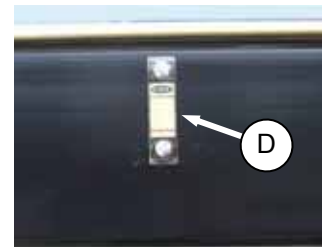

- g. Check oil level in site glass (D) on the left side of the APT, is between ADD and FULL.
- h. If necessary add single grade trans-hydraulic oil at filler pipe (E).

#### RECOMMENDED OILS

Petro-Canada Duratran	Chevron 1000 THF
Case IH Hy-Tran Plus®	Agco Power Fluid 821XL
New Holland Hydraul	Esso/Exxon Hydraul 56
Shell Donax TD	John Deere Quatro® J20C

## UNLOADING AND ASSEMBLY

### STEP 9. CONNECT LIFT HOSE

#### IMPORTANT

Hoses should be routed so there are no twists or sharp bends and no locations where contact with the frame is likely. Ensure that there is sufficient length of hose and wiring in span to accommodate full swing of APT in both directions. Relocate plastic ties if necessary to provide suitable slack in hoses and wiring.

#### IMPORTANT

To prevent contamination of the hydraulic system, extreme care must be taken to avoid dirt entering at connection points. To minimize exposure to contamination, remove cap from one hose and its mating connection and connect before removing other caps and plugs.

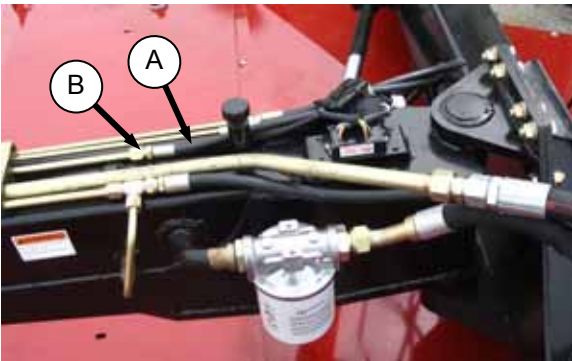

- a. Connect the lift cylinder hose (A) to the fitting (B) on the APT.

### STEP 10. CONNECT WIRING HARNESS

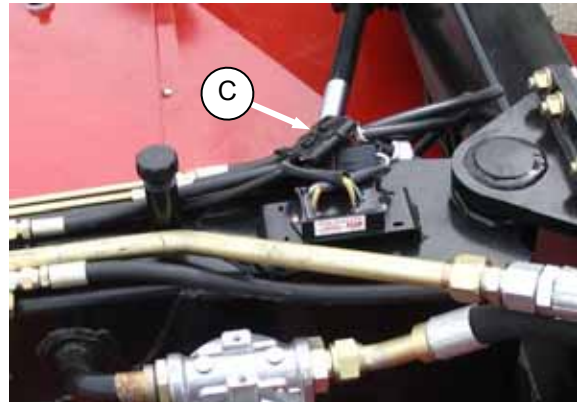

- b. Connect electrical wiring harness (C) at rear of APT as shown.

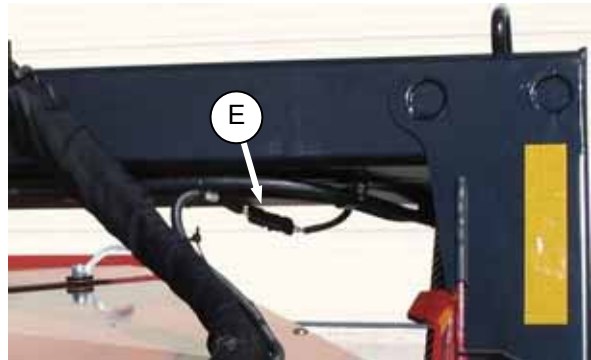

- c. On 16 ft. header connect light harness to connector (E) at LH side of carrier frame.

## UNLOADING AND ASSEMBLY

### STEP 11. INSTALL HYDRAULIC MOTOR



- a. Remove shipping wire that holds motor to steering cylinder.

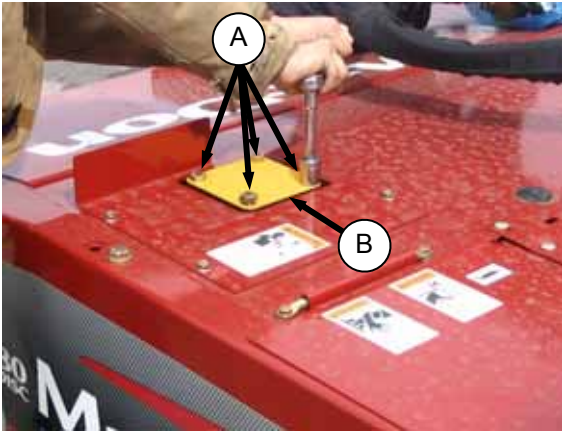

- b. Remove four bolts (A) securing plate (B) to gearbox and remove plate. Retain bolts.

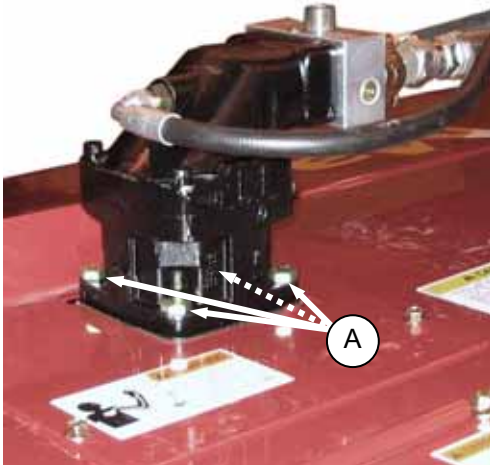

- c. Position motor on gearbox as shown and re-install the four bolts (A). Torque to 103 ft-lbf (140 N·m).

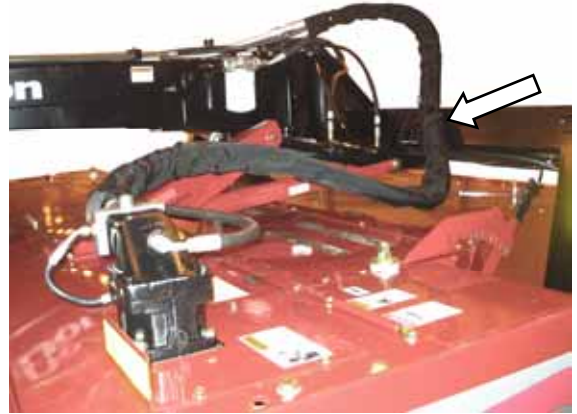

- d. Route hoses through hose guides.

#### NOTE

*If required, loosen the hose swivel fittings at the motor ports to remove any twist in the hose routing from the APT. Do not loosen the clamp type fitting.*

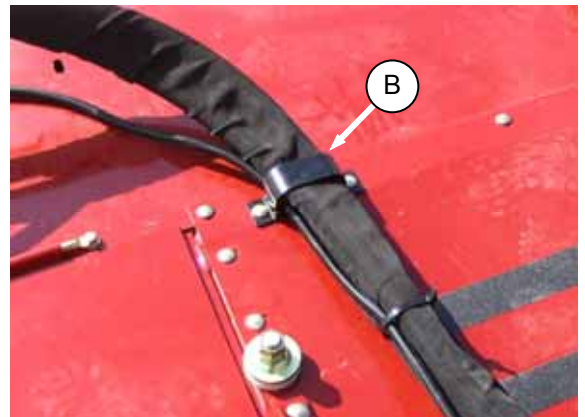

- e. On 16 ft headers, remove bracket (B) and secure hoses and wiring harness to header with bracket (B). Adjust hoses as required.

## UNLOADING AND ASSEMBLY

### STEP 12. INSTALL WHEELS



- a. Attach a lifting chain to the hook at one end of the carrier frame and to a forklift or equivalent.
- b. Lift frame so that the cutterbar is slightly off the ground.

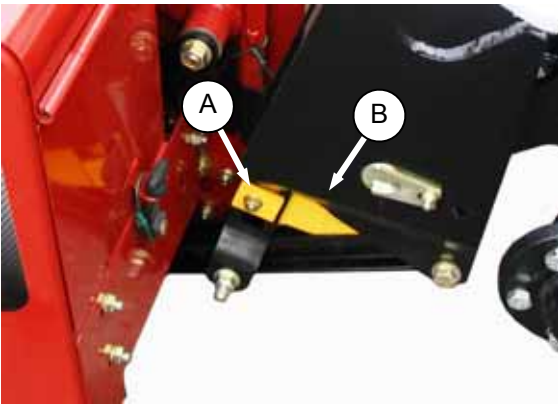

- c. Remove bolt (A) securing shipping wedge (B) at the lower lift link and remove wedge.



### CAUTION

Do not drive out this bolt. If carrier frame is lifted high enough, bolt becomes free to remove.

- d. Remove wheel bolts from wheel hub.



### CAUTION

When installing wheel be sure to use the holes that are countersunk to match bolt head profile. The uncountersunk holes do not seat the bolts correctly.

#### IMPORTANT

Remove excess paint from tapered surface of bolt holes in wheel.

- e. Install wheel with existing bolts. Be sure valve stem points away from wheel support.

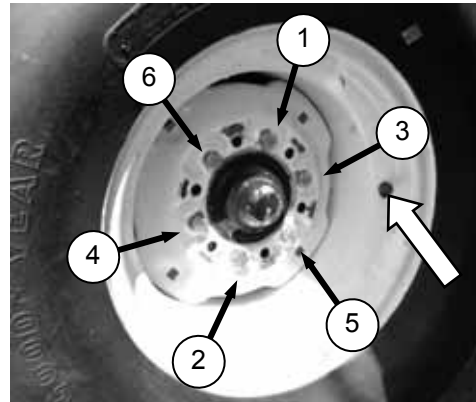

- f. Torque bolts to 120 ft lbf (160 N-m) following tightening sequence shown.

#### IMPORTANT

Follow proper bolt tightening sequence shown.

- g. Lower carrier frame and repeat steps a. to f. to install the other wheel.
- h. Check tires inflated to 30 psi (207 kPa).

## UNLOADING AND ASSEMBLY

### STEP 13. INSTALL CENTER LINK

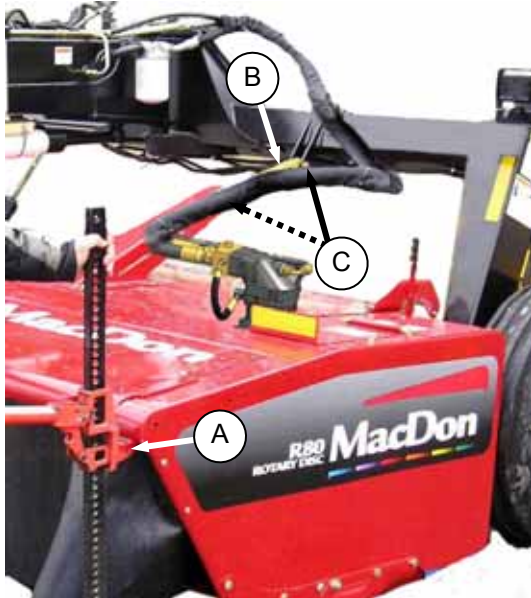

- Lift front corner of header using a lift jack (A) until the shipping brace (B) is loose.
- Remove clevis pins (C) securing brace to header and carrier frame and remove brace (B). Retain pins for re-installation.
- Lower header to ground.
- Raise front of APT with the jack to allow installation of the adjustable mechanical center link or optional hydraulic link.

#### A. MECHANICAL LINK

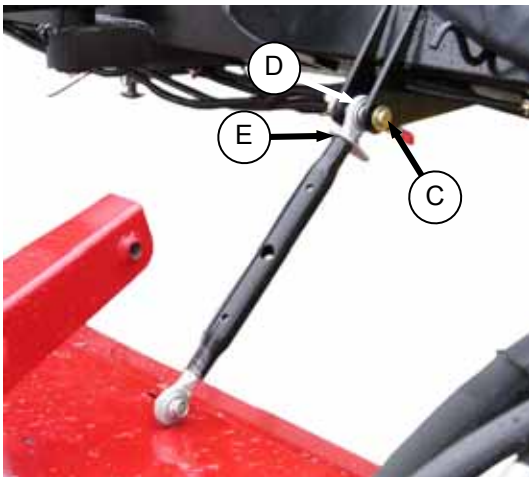

- Attach mechanical link (D) to carrier frame with clevis pin (C). Secure with cotter pin.
- Loosen nut (E).
- Rotate the turnbuckle sleeve (F) so that link can be connected to header. Insert clevis pin

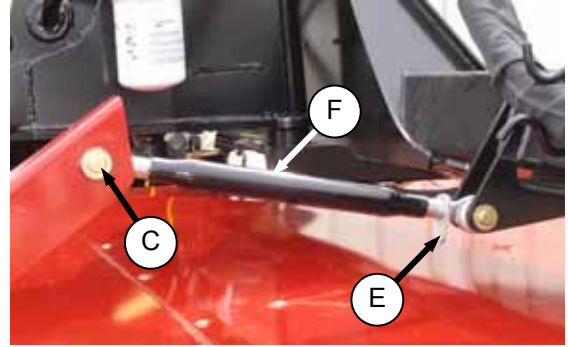

(C) when holes are aligned and secure with cotter pin.

- Snug up nut (E) but do not over tighten. A slight tap with a small hammer is sufficient.

#### B. HYDRAULIC LINK

- Refer to instructions provided with hydraulic link kit for installation procedures.

### STEP 14. REMOVE BANDING AT LIFT CYLINDERS



- Cut the banding that secures the LH and RH lift cylinders to the carrier frame.

## UNLOADING AND ASSEMBLY

### STEP 15. ATTACH MOWER CONDITIONER TO TRACTOR



#### CAUTION

Shut off tractor, engage parking brake and remove key before working around hitch.

#### A. DRAWBAR TYPE HITCH

##### I. SETUP THE DRAWBAR

Adjust tractor drawbar to meet ASAE Standard specifications as listed below.

DIMENSION	1000 RPM PTO	
	1.37" DIA.	1.75" DIA.
X	16 in. (406 mm)	20 in. (508 mm)
Y	6-12 in. (152-305 mm) 8 in. (203 mm) Recommended	
Z	13-17 in. (330-432 mm) 16 in. (406 mm) Recommended	

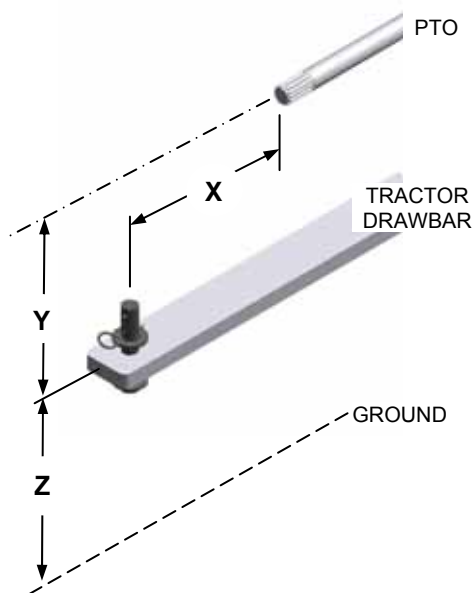

##### II. ATTACH DRAWBAR EXTENSION

- a. Secure the drawbar so the hitch-pin hole is directly below the driveline.
- b. Unpack hitch parts bundle.
- c. Attach the drawbar extension (A) to the tractor drawbar as follows and as shown:

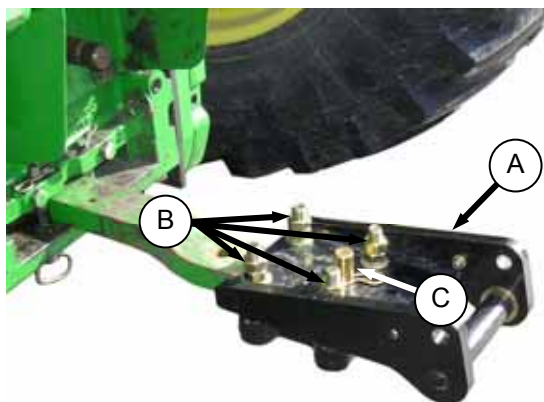

6. Loosen bolts (B) on extension assembly and slide onto drawbar. Install pin (C).
1. Tighten the four bolts to 265 ft-lbf (359 N·m).



#### CAUTION

Never attach mower-conditioner to tractor rear axle or three-point hitch arms.

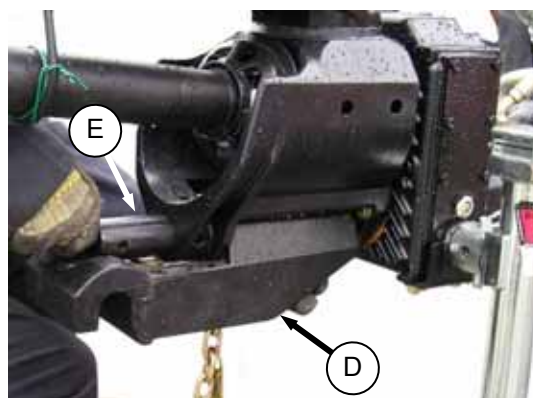

- d. Attach the swivel hitch member (D) with pin (E) onto the mower-conditioner APT.

*(continued next page)*

## UNLOADING AND ASSEMBLY

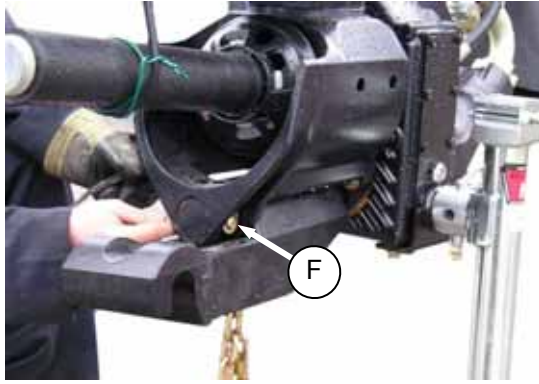

- e. Secure swivel pin with pin (F) and lynch pin.

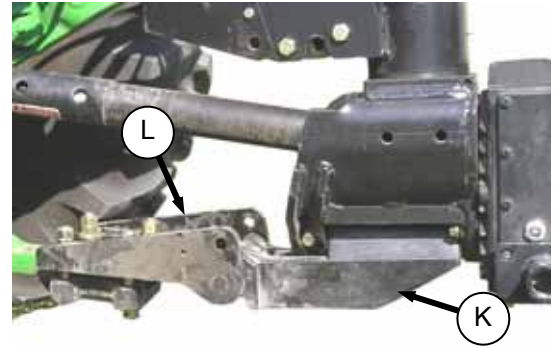

- c. Back up tractor to APT and align hitch member (K) with pin on drawbar extension (L). Lower jack so that member engages pin.

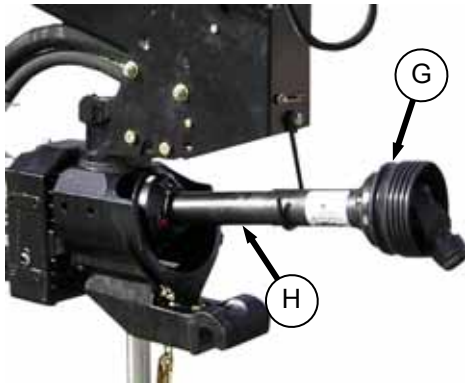

- f. Assemble PTO driveline male half (G) onto PTO shaft (H) on APT. Push male half so that PTO shaft is at its fully compressed length.

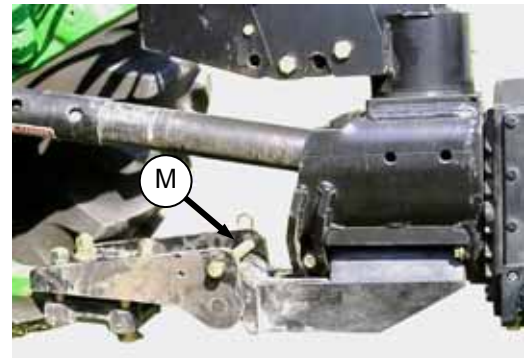

- d. Install hitch-pin (M) and secure with hairpin.  
e. Attach driveline (N) to tractor PTO shaft as follows:

### III. ATTACH MOWER CONDITIONER TO TRACTOR



#### CAUTION

Stop engine and remove key from ignition before leaving operator's seat for any reason. A child or even a pet could engage an idling machine.

- a. Set park brake, stop engine and remove key.

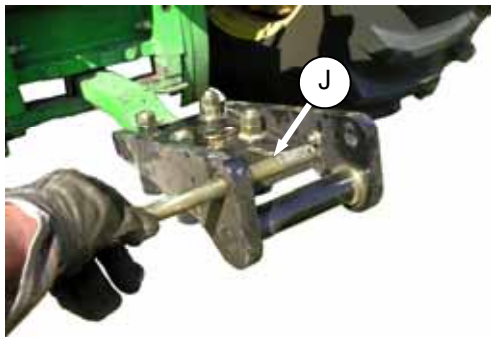

- b. Remove pin (J) from drawbar extension.

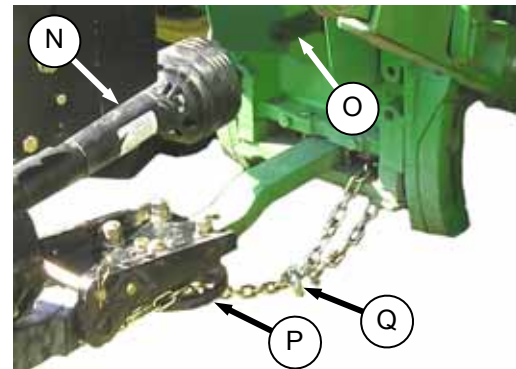

1. Position driveshaft onto tractor PTO shaft (O).
  2. Pull back collar on driveshaft and push driveshaft until it locks. Release collar.
- f. Route APT safety chain from mower-conditioner through chain support (P), around drawbar support and lock the hook (Q) on chain.

#### IMPORTANT

Adjust chain length to remove all slack except what is needed for turns.

*(continued next page)*

## UNLOADING AND ASSEMBLY

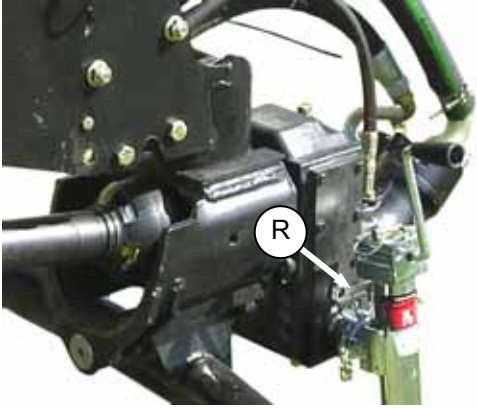

- g. Pull pin (R) securing jack and move jack to storage position on side of APT.

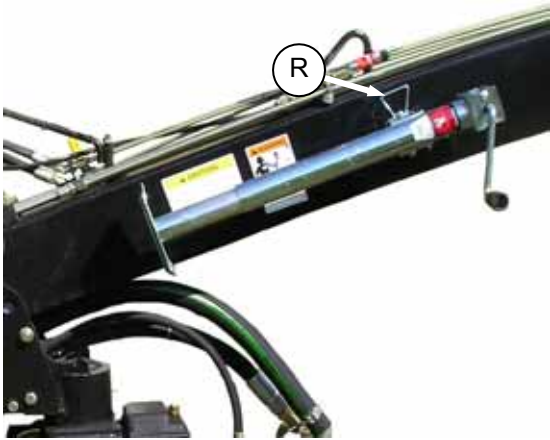

- h. Secure jack with pin (R).

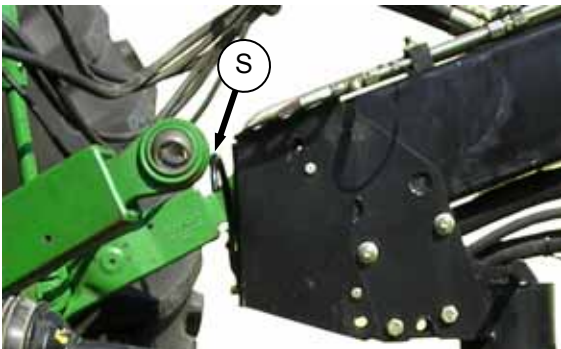

- i. Rotate driveline storage hook (S) to upper position.
- j. Proceed to STEP 16. ATTACH HYDRAULICS AND ELECTRICAL.

## UNLOADING AND ASSEMBLY

### B. 3-POINT HITCH (CAT. II, III, OR IIIN)

#### I. INSTALL THE 3-POINT HITCH YOKE

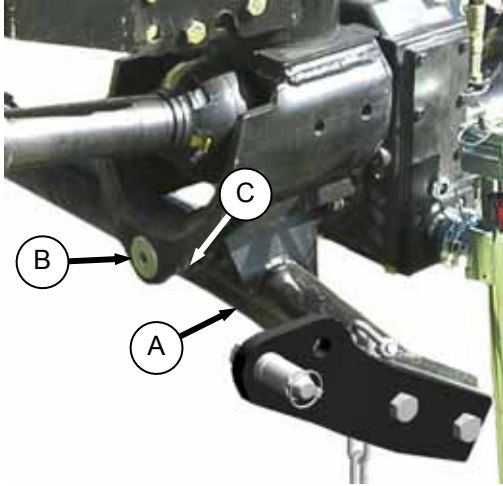

- Attach the 3 point hitch yoke (A) to the APT with pin (B). The installation is similar to that described in the previous section.
- Secure pin (B) with clevis pin (C), washers, and cotter pin.
- The arms (D) on APT yoke can be set up to suit the tractor hitch arms:

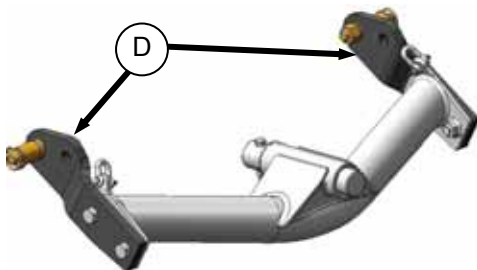

CATEGORY II or IIIN

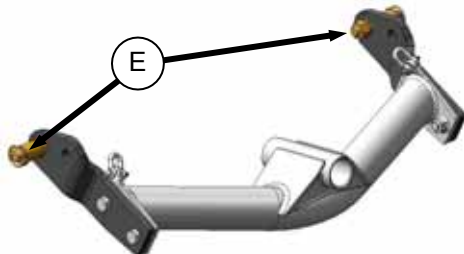

CATEGORY III

- Remove pins (E) from arms.
- Remove arms (D) from APT yoke.
- Re-install arms on opposite ends of yoke as shown.
- Re-install pins (E) in arms.

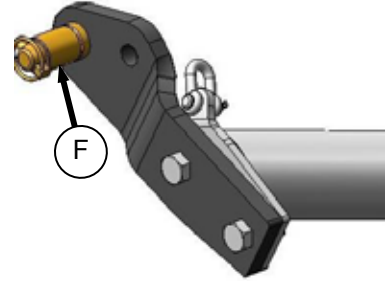

#### NOTE

Bushings (F) on pins can be removed to suit hole size in tractor hitch arms.

#### II. ATTACH MOWER-CONDITIONER TO TRACTOR

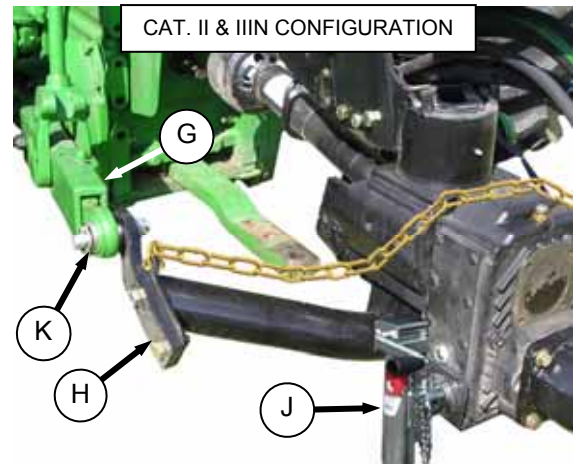

CAT. II & IIIN CONFIGURATION

- Position tractor and align tractor hitch arms (G) with windrower arms (H). Use jack (J) to adjust height of windrower APT.
- Secure arms with lynch pins (K).
- Install anti-sway bars on tractor hitch to stabilize lateral movement of hitch arms (G). Refer to your tractor operator's manual.

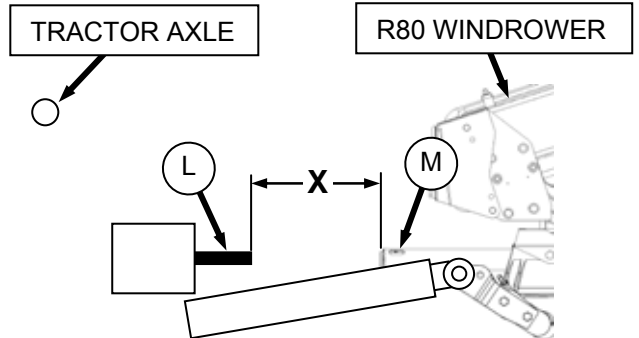

- Check distance 'X' between tractor PTO shaft (L) and implement input shaft (M) (without the front half of the driveline attached).

(continued next page)

## UNLOADING AND ASSEMBLY

- e. The measurement must not exceed the following:

DRIVELINE SHAFT SIZE	DISTANCE 'X'
1.375 in. (34 mm)	14 in. (356 mm)
1.75 in. (43 mm)	17 in. (432 mm)

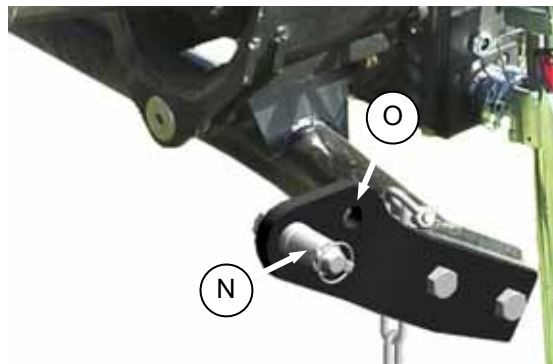

- f. Change locations of pins (N) in APT arms to hole (O) to locate implement closer to tractor if necessary.

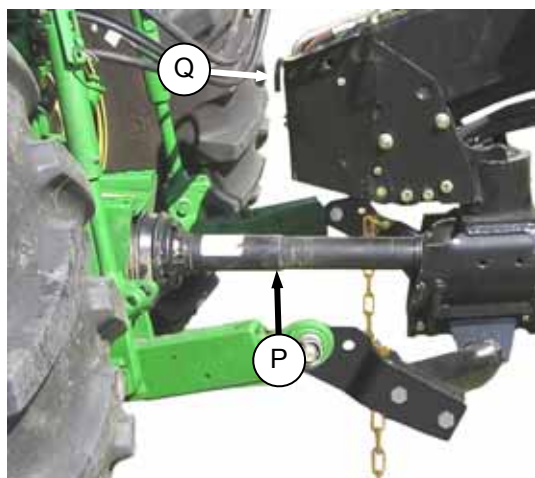

- g. Position mower conditioner driveline (P) onto tractor PTO shaft. Driveline should be approximately level.
- h. Pull back collar on driveshaft and push driveshaft until it locks. Release collar.
- i. Rotate driveline storage hook (Q) to upward position.

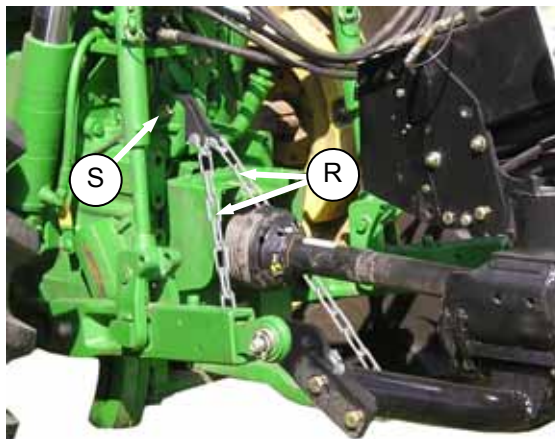

- j. Attach down-stop chains (R) to pin (S) on tractor.



### CAUTION

The downstop chains limit the downward travel of the 3-point hitch lifting arms to prevent damaging the PTO driveline on the mower-conditioner. Ensure chains are attached when operating the mower-conditioner.

- k. Adjust chain length as required by relocating end link at tractor end of chain as follows:

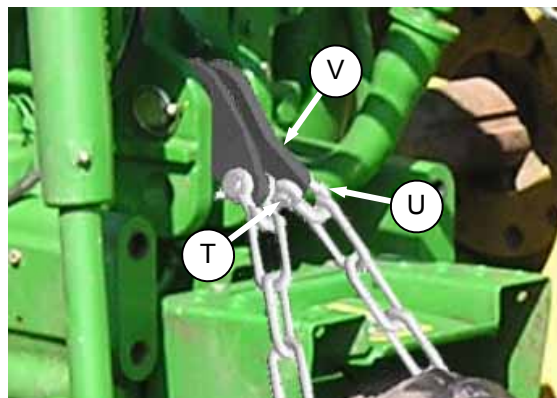

1. Remove cotter pin and clevis pin (T) to disconnect open link (U) and end link (V).
2. Relocate open link (U) to new location on chain and re-attach to end link (V) with clevis pin (T). Chains do not need to be tight.
3. Secure clevis pin with cotter pin.

*(continued next page)*

## UNLOADING AND ASSEMBLY

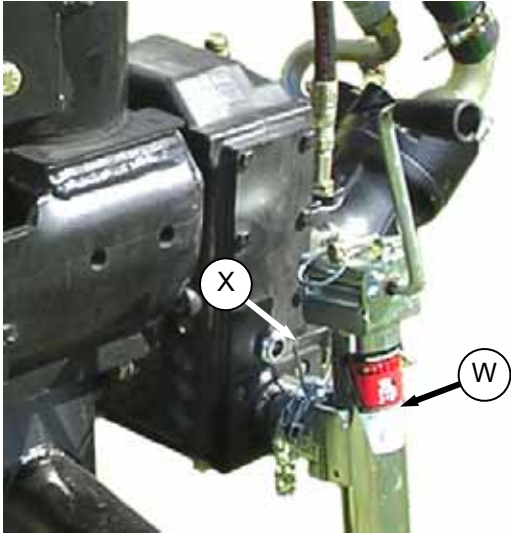

- I. Raise jack (W), pull pin (X), and remove jack from working location.

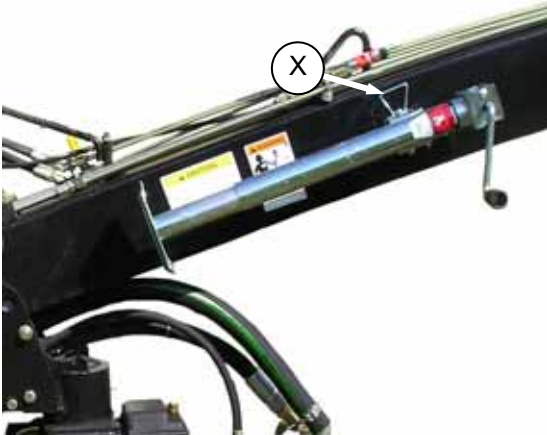

- m. Move jack to storage position on side of (APT), and secure with pin (X).

## UNLOADING AND ASSEMBLY

### STEP 16. ATTACH HYDRAULICS AND ELECTRICAL



#### WARNING

Do not use remote hydraulic system pressures over 3000 psi (20684 kPa). Check your tractor manual for remote system pressure.

- a. Install quick disconnect couplers onto hydraulic hoses at front of APT as per following table. Use #8 ORB (3/4 inch – 16 UNF Thread).

SYSTEM	HOSE	TRACTOR HYDRAULICS
Steering	A (2 Hoses)	Control 1
Lift	B (1 Hose)	Control 2
Header Tilt	C (2 Hoses)	Control 3

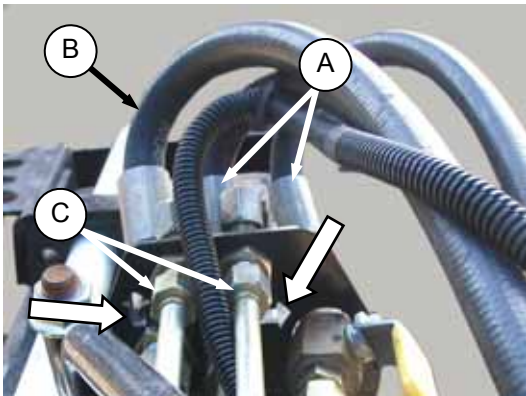

#### NOTE

Arrows cut into plate indicate system for hoses. LIFT ↑ STEERING ↔

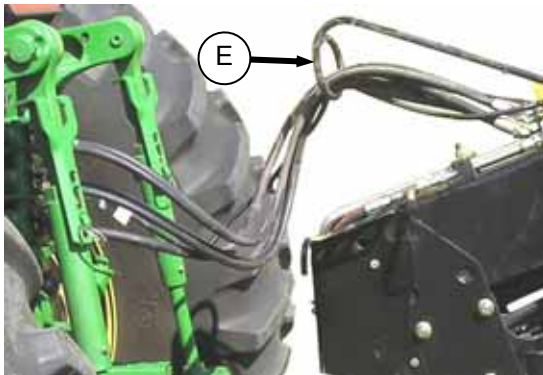

- b. Ensure hoses are routed through guide (E) to provide proper hose arc as shown.

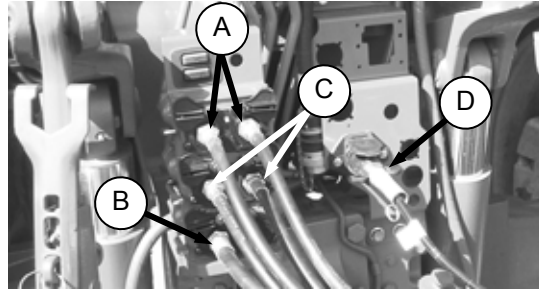

- c. Connect two **steering** cylinder hoses (A) as follows:

CONTROL LEVER POSITION	CYLINDER MOVEMENT	MOWER-CONDITIONER DIRECTION
Forward	Extend	Right
Backward	Retract	Left

- d. Connect one **lift** cylinder hose (B) as follows:

CONTROL LEVER POSITION	CYLINDER MOVEMENT	HEADER MOVEMENT
Forward	Retract	Lower
Backward	Extend	Raise

- e. Connect two **header tilt** cylinder hoses (C) as follows: (Not required with mechanical center link).

CONTROL LEVER POSITION	CYLINDER MOVEMENT	HEADER MOVEMENT
Forward	Retract	Lower
Backward	Extend	Raise

- f. Connect the mower-conditioner wiring harness connector (D) to tractor. The connector is designed to fit tractors equipped with a round 7-pin receptacle (SAE J560).

#### IMPORTANT

Older model tractors will have Pin #4 (F) energized as an accessory circuit. The R80 mower conditioner uses this pin position (G) for brake lights. Check that Pin #4 in the tractor receptacle is not constantly energized – see tractor's operator's manual and remove the appropriate fuse if required.

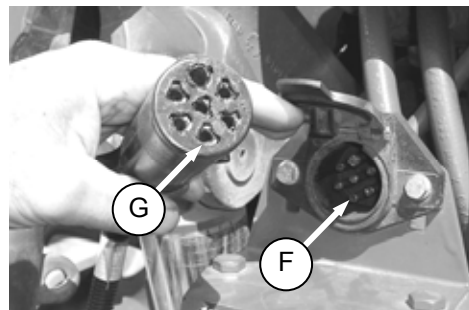

## UNLOADING AND ASSEMBLY

### STEP 17. INSTALL STEERING CYLINDER

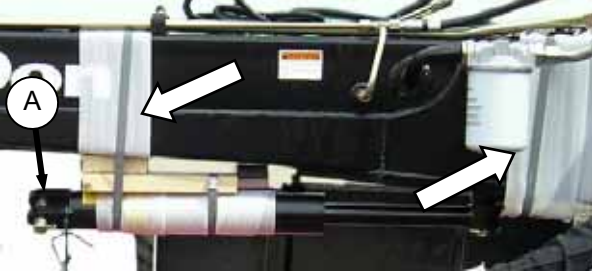

- Cut the banding that secures the cylinder to the APT and swing the cylinder out from under the APT.
- Cut banding around cylinder and remove shipping material from cylinder.
- Remove the pin (A) from barrel end of cylinder and retain for re-installation.

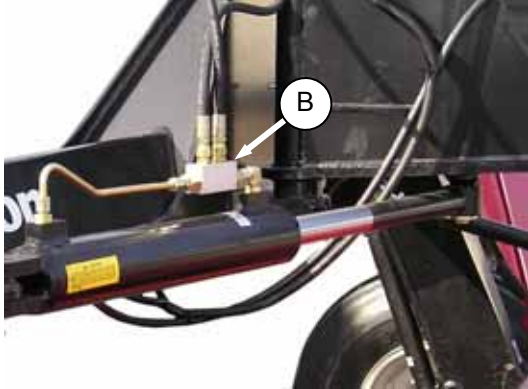

- Manually rotate the cylinder barrel so that the check valve (B) is positioned directly above cylinder. Do not attach cylinder to frame at this time.



#### IMPORTANT

To allow APT to swing, the valve on the APT must be in the working or open position (handle in line with APT).



#### DANGER

**Never start or move the machine until you are sure all bystanders have cleared the area.**

- Start tractor.
- Stroke the cylinder to full extension and retraction 5 or 6 times to ensure that cylinder and hydraulic lines are fully charged with oil.
- Stroke the cylinder so that the cylinder can be slipped onto the bracket (C) on the frame.



#### CAUTION

**Stop engine and remove key from ignition before leaving operator's seat for any reason. A child or even a pet could engage an idling machine.**

- Stop engine and remove key.

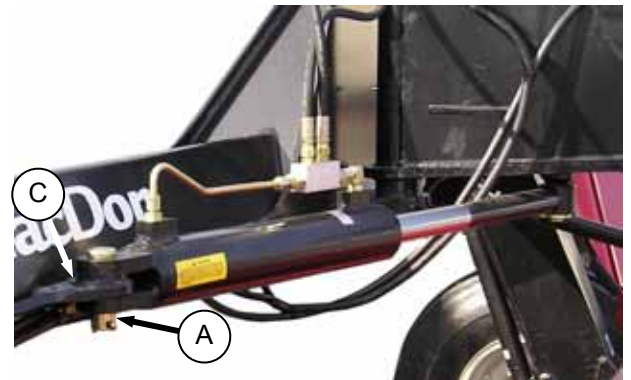

- Slip cylinder onto bracket (C) and install pin (A) if holes are aligned. If holes are not aligned, stroke cylinder or pivot header until pin can be installed. Secure pin (A) with cotter pin.

## UNLOADING AND ASSEMBLY

### STEP 18. FILL LIFT CYLINDERS



- a. Open lift cylinder lock out valve on both lift cylinders.



#### **DANGER**

**Never start or move the machine until you are sure all bystanders have cleared the area.**

- b. Start tractor.
- c. Cycle the header lift cylinders five or six times to maximum lift to fully charge the cylinders and hydraulic lines.
- d. Raise header to full height, stop tractor and remove key.



#### **CAUTION**

**Stop engine and remove key from ignition before leaving operator's seat for any reason. A child or even a pet could engage an idling machine.**

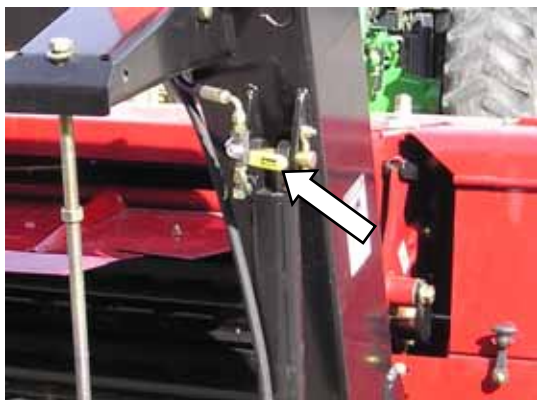

- e. Close lock-out valve on both lift cylinders.

## UNLOADING AND ASSEMBLY

### STEP 19. INSTALL FLOAT SPRINGS

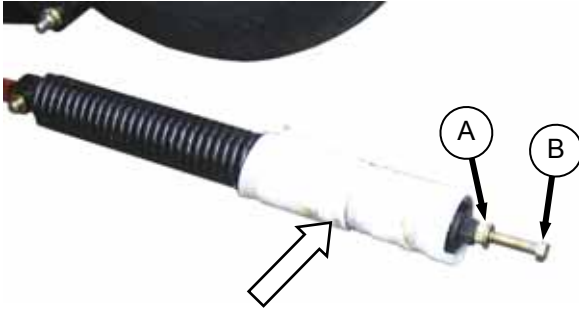

- Remove packing material from float spring.
- Loosen jam-nut (A) and remove drawbolt (B) from spring.

#### IMPORTANT

On the 13 ft. mower-conditioner, the float spring for the LH side has an internal spring and is heavier than the RH spring. Ensure that heavier spring is installed at LH side.

#### NOTE

*The 16 ft mower-conditioner float springs have internal springs on both sides.*

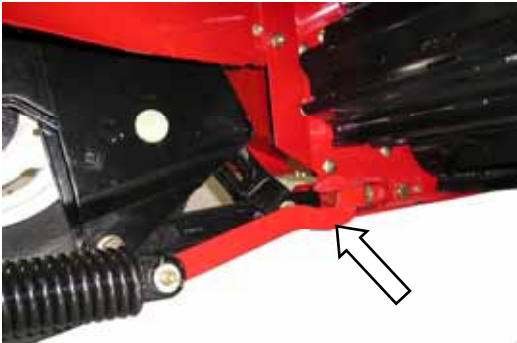

- Insert hook into bracket on header frame.

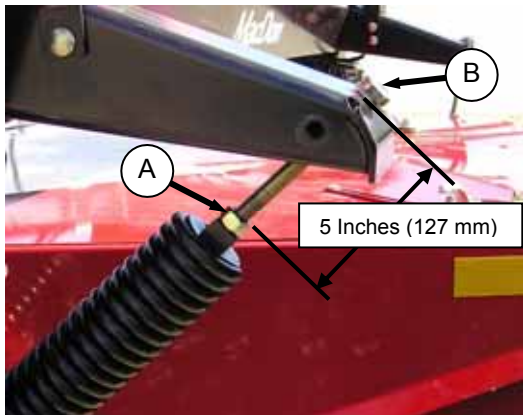

- Install drawbolt through anchor on carrier frame and reinstall into spring.

- Tighten spring drawbolt so that distance between spring anchor to locknut is approximately 5 inches (127 mm).



### CAUTION

To prevent damage to the float spring system, do not lower the header before tightening jam nuts (A) against the springs.

#### IMPORTANT

Because header weight transfers to outside tire whenever mower conditioner is swung from one side to the other, tires must be fully inflated to 30 psi (207 kPa) to minimize effects on header float.

- Lift either end of the header just off the ground. Header flotation springs are normally set to 95-105 lbf (426-471 N) force is required to lift the header.
- Adjust springs as required with drawbolt (B).
- Tighten jam nuts (A) securely against float springs.

## UNLOADING AND ASSEMBLY

### STEP 20. INSTALL FORMING SHIELD

#### A. INSTALL SUPPORTS

- a. Remove supports and hardware bag that were removed from shipping locations in earlier steps.

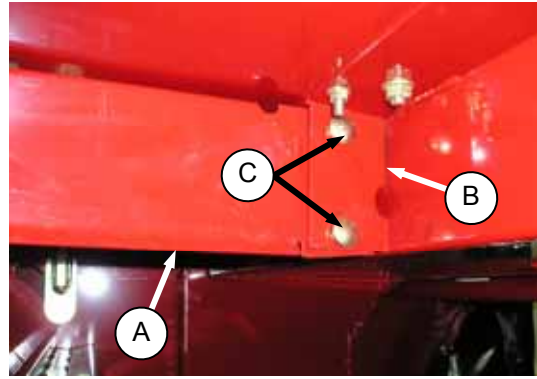

- d. Locate support (A) on outboard side of mounting bracket (B).  
e. Retrieve two ½ x 1.0 lg. carriage bolts (C) and locknuts from hardware bag and secure support to bracket. Do not fully tighten bolts.  
f. Repeat for other support.

#### B. INSTALL FORMING SHIELD

- b. Remove protective moulding from behind cutterbar doors (2 places).



- a. Place forming shield on lift forks and position forming shield adjacent to supports.  
b. Slide forming shield onto supports and back fork lift away.

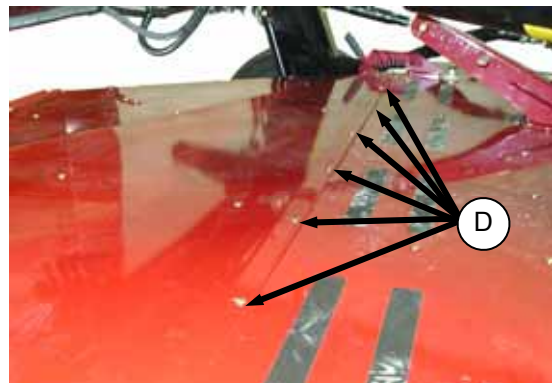
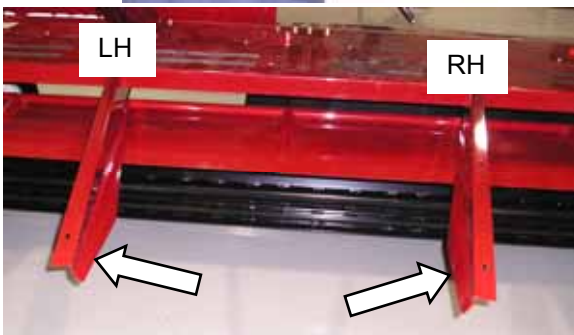

- c. Insert support from rear of header as shown. The supports are handed and lower flanges must face each other.

- c. Locate shield to align holes in forward row. Install two 3/8 x 0.75 lg. bolts (D) and nuts in forward row to hold shield. Do not tighten.  
d. Install 3/8 x 0.75 lg. bolts (D) and nuts in remaining holes in forward row, except at corners. Do not tighten.

(continued next page)

## UNLOADING AND ASSEMBLY

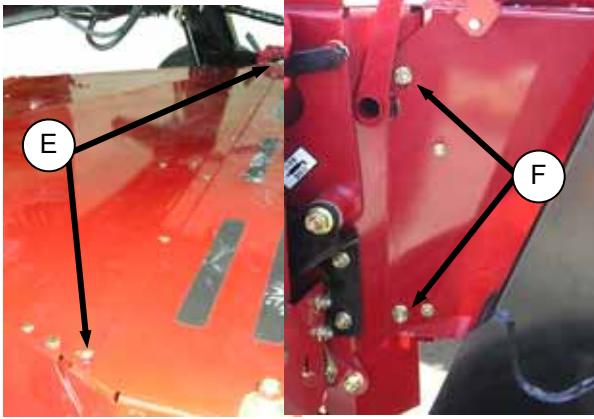

- e. Install two 3/8 x 1.0 lg. (E) bolts and nuts in holes at corners but do not tighten.
- f. Install two 1/2 x 1.0 lg. bolts (F) and nuts on each side. Do not tighten.

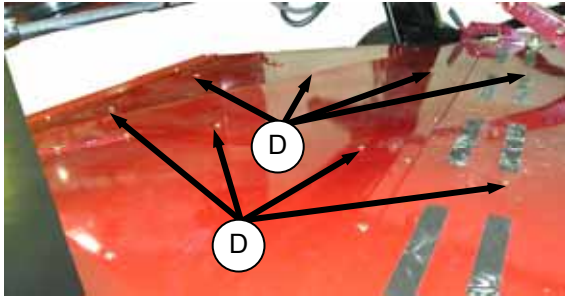

- g. Install eight 3/8 x 0.75 lg. bolts (D) and nuts at support locations.



- h. Lift aft end of forming shield so that side deflectors clear float springs and tighten all bolts.

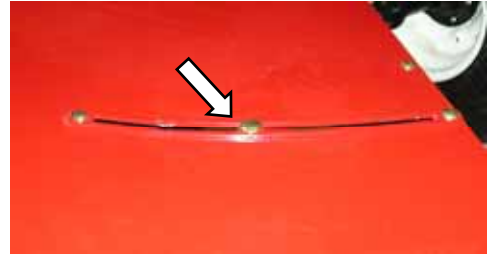

- i. Remove bolt and nut at two places and discard.

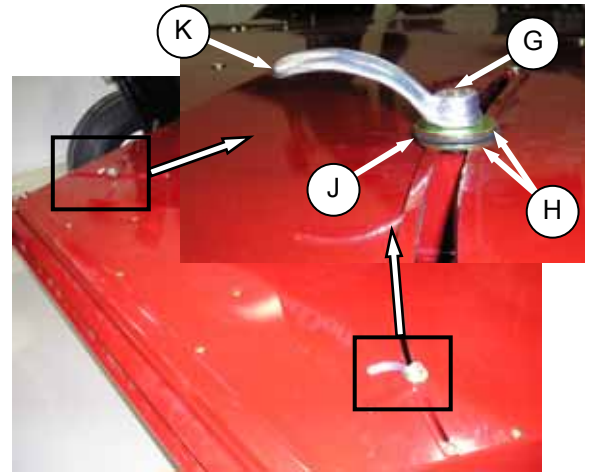

- j. Retrieve hardware as supplied and install 1/2 x 1.75 lg. bolt (G) from underneath, washers (H), rubber washer (J), and handle (K) as shown at 2 places.

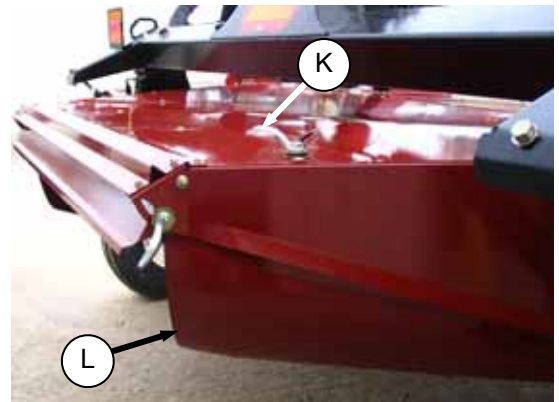

- k. Position side deflectors (L) at mid-point and tighten handles (K).
- l. Position crop deflector handle at mid-position.



## UNLOADING AND ASSEMBLY

### STEP 21. INSTALL TALL CROP FEED PLATES

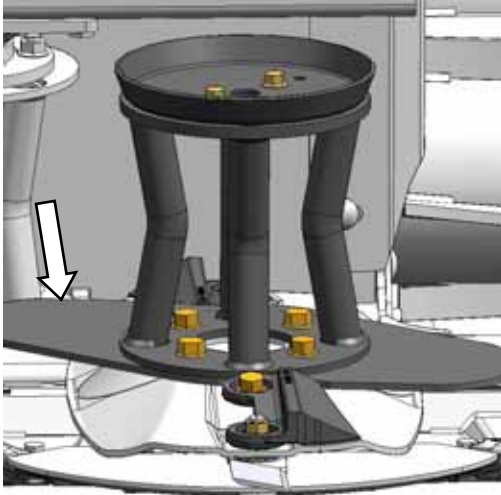

The tall crop feed plates assist the feeding of tall crops into the conditioner by encouraging material flow from behind the hourglass deflectors. They will degrade the cutting performance of the cutterbar if they are used in medium to light alfalfa, and so should not be installed in those types of crops. The feed plates are designed for installation on the two inboard hourglass deflectors and only on 16 ft headers. They are stored inside the RH side drive compartment.

Proceed to STEP 22 INSTALL OPTIONS if Tall Crop Feed Plates will not be installed, otherwise proceed as follows:

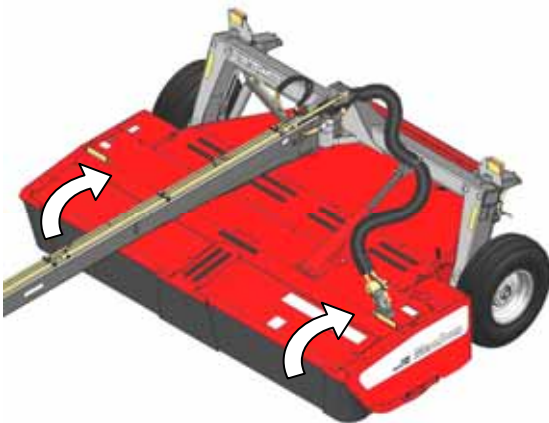

a. Open cutterbar doors.

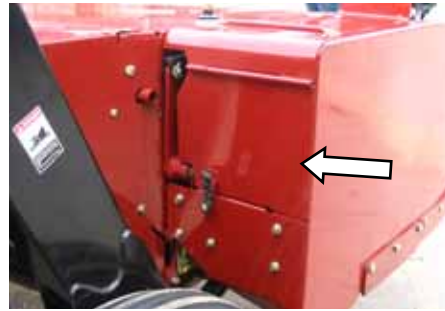

b. Open RH side drive shield.

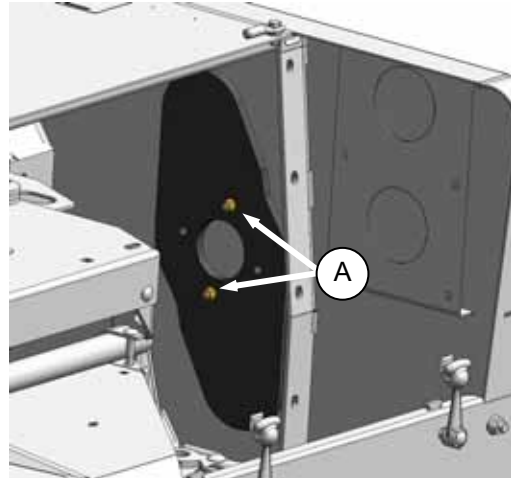

c. Remove nuts (A) securing feed plates to side of compartment and remove plates.



### CAUTION

**Exercise caution when working around the blades. Blades are sharp and can cause serious injury. Wear gloves when handling blades.**

d. Place a block of wood between discs to prevent deflector from turning.

*(continued next page)*

## UNLOADING AND ASSEMBLY

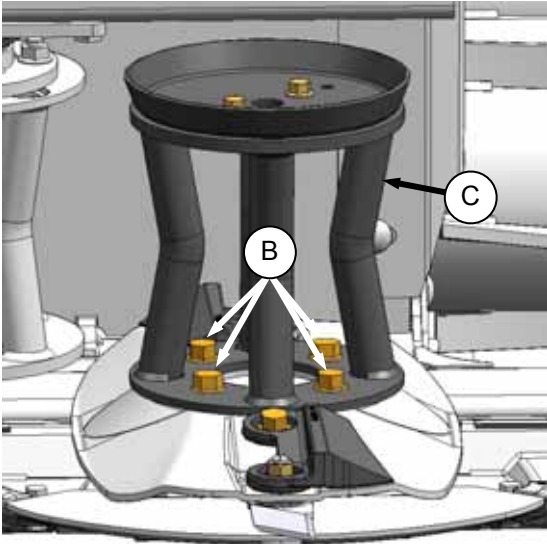

- j. Remove block if used and manually rotate discs to check for interference of feed plate and adjacent parts.

- e. Remove four bolts (B) and remove inboard hourglass driven deflector (C).

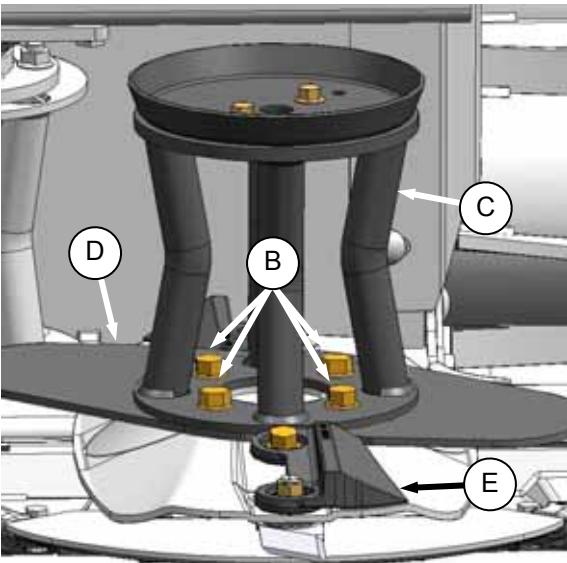

- f. Locate feed plate (P) on the disc ensuring that hole in feed plate registers on disc. Position plate approximately as shown and align holes.

### IMPORTANT

Feed plate should be located so that when holes are aligned, it is closer to the accelerator leading edge (E) than the trailing edge.

- g. Re-position deflector (C) and align holes.
- h. Re-install bolts (B) and tighten to 66 ft·lbf (90 N·m). Torque nuts (F) to 100 ft·lbf (135 N·m).
- i. Repeat above steps for opposite side.

## UNLOADING AND ASSEMBLY

### STEP 22. INSTALL OPTIONS

#### A. TALL CROP DIVIDER KIT

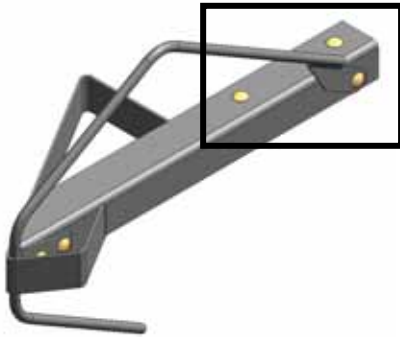

- Unpack kit and remove the three bolts and nuts indicated.

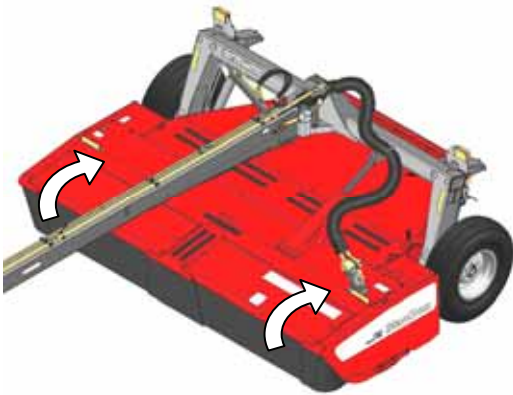

- Open cutterbar doors.

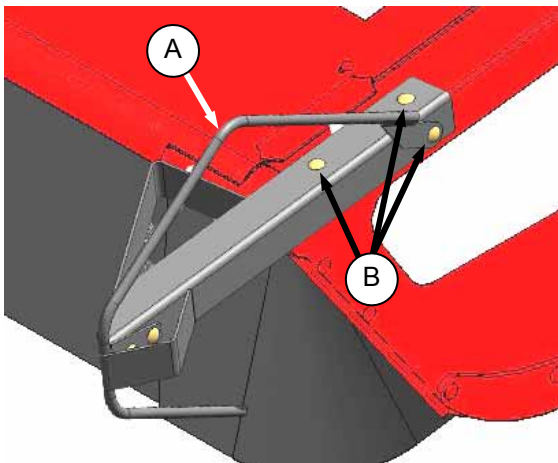

- Locate LH divider (A) on header LH front corner and install with three bolts and nuts in existing holes. Tighten hardware.
- Repeat for RH side.

#### B. SHOE LIFT KIT

- Unpack kit.
- Start tractor and raise header fully.



### WARNING

To avoid bodily injury or death from unexpected start-up or fall of raised machine, stop engine, remove key and engage lift cylinder stops before going under machine for any reason.

- Stop engine, remove key, and engage lift cylinder valves.
- Install a lift on each of the two end skid shoes, and on two additional shoes at equi-distant locations as follows:

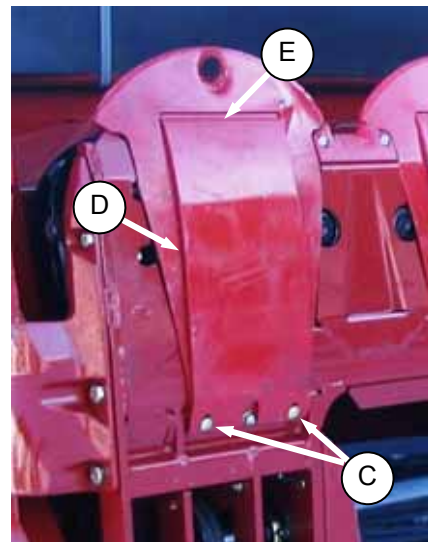

- Remove two bolts (C), pivot skid shoe (D), and remove from slot (E) in rock guard.

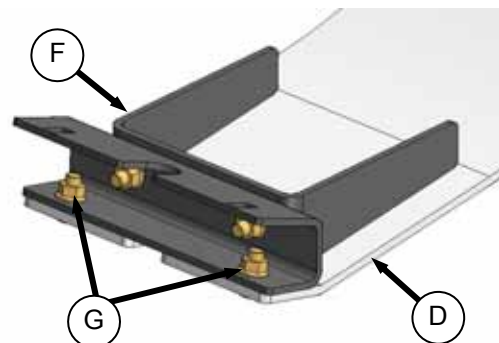

- Attach shoe lift (F) to skid shoe as shown with hardware (G) supplied in kit. Tighten bolts.
- Position skid shoe (D) joggled end in rock guard slot (E) and locate aft end with lift (F) against rock guard. Secure with existing bolts (C).

## UNLOADING AND ASSEMBLY

### STEP 23. LUBRICATE THE MOWER CONDITIONER



#### WARNING

To avoid bodily injury or death from unexpected start-up or fall of raised machine, stop engine, remove key and engage lift cylinder stops before going under machine for any reason.

The mower conditioner has been lubricated at the factory. However, it is recommended to lubricate the mower conditioner prior to delivery to offset the effects of weather during outside storage and transport, and to familiarize the dealer with the machine.

High Temp. Extreme Pressure (EP2) Performance With 1% Max Molybdenum Disulphide (NLGI Grade 2).Lithium Base



Refer to the illustrations on the following pages for lubrication points.

- Wipe grease fitting with a clean cloth before greasing, to avoid injecting dirt and grit.
- Inject grease through fitting with grease gun until grease overflows fitting, except where noted.
- Leave excess grease on fitting to keep out dirt.
- Replace any loose or broken fittings immediately.
- If fitting will not take grease, remove and clean thoroughly. Also clean lubricant passageway. Replace fitting if necessary.

*(continued next page)*

### 13 FT

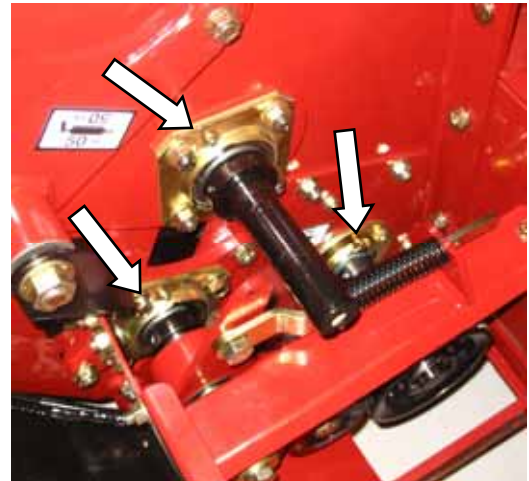

ROLL SHAFT BEARINGS (3 PLCS)

10% MOLY GREASE IS RECOMMENDED FOR DRIVELINE SHAFT SLIP JOINT ONLY

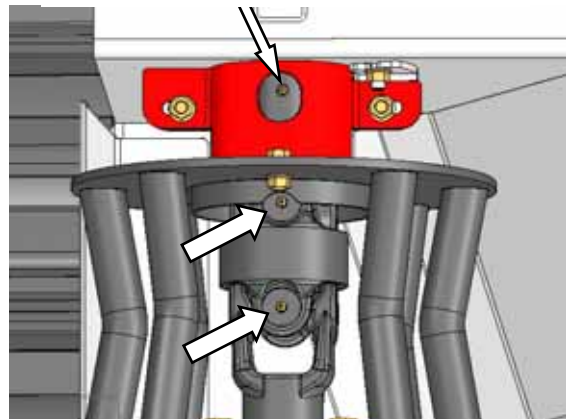

DRIVELINE UNIVERSALS (2 PLCS)  
DRIVESHAFT (1 PLC)

# UNLOADING AND ASSEMBLY

## LUBRICATION – 13 FT (cont'd)

High Temp. Extreme Pressure (EP2) Performance With 1% Max Molybdenum Disulphide (NLGI Grade 2).Lithium Base



CHECK PLUG  
Oil should slightly run out when removed.



GEARBOX OIL LEVEL

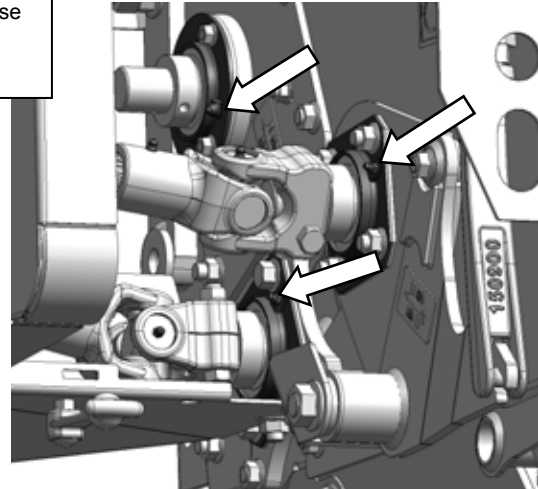
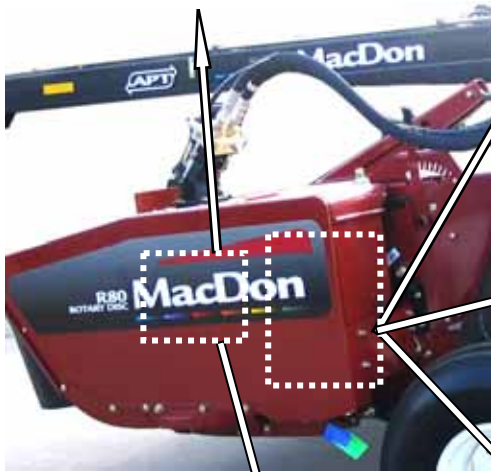

ROLL SHAFT BEARINGS (3 PLCS)

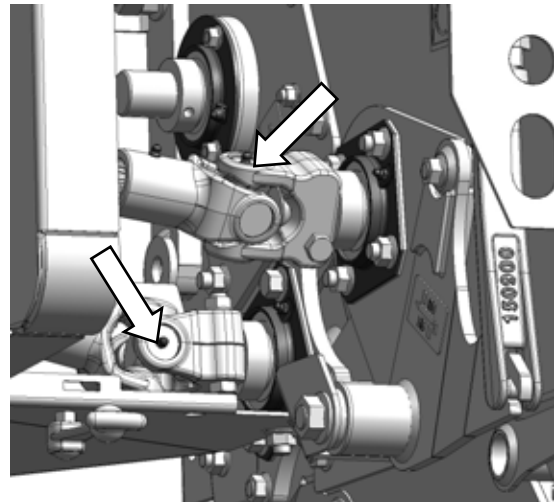

DRIVELINE UNIVERSALS (2 PLCS)

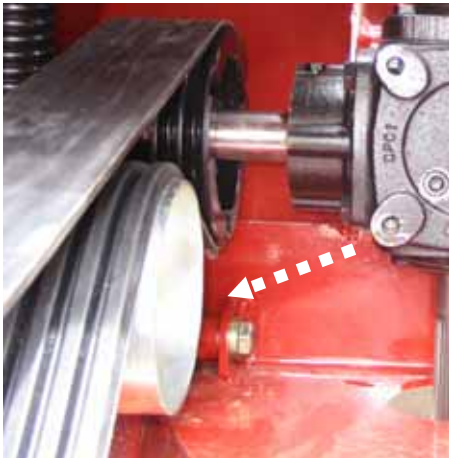

BELT TENSIONER PIVOT (1 PLC)

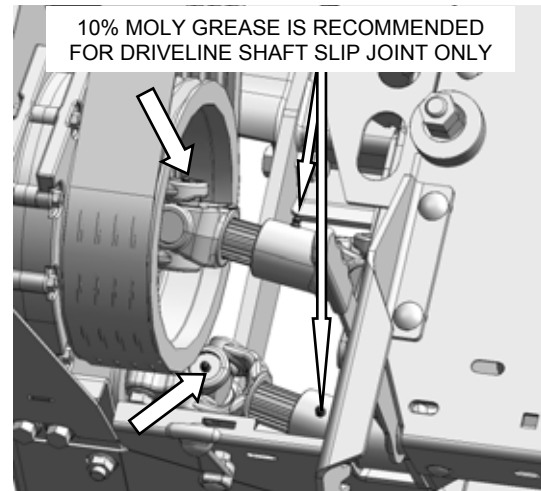

10% MOLY GREASE IS RECOMMENDED FOR DRIVELINE SHAFT SLIP JOINT ONLY

DRIVELINE UNIVERSALS (2 PLCS)  
DRIVELINE SHAFT (2 PLCS)

# UNLOADING AND ASSEMBLY

## LUBRICATION – 16 FT

High Temp. Extreme Pressure (EP2) Performance With 1% Max Molybdenum Disulphide (NLGI Grade 2). Lithium Base

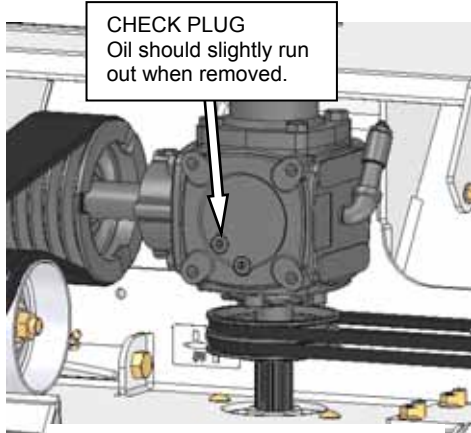



CHECK PLUG  
Oil should slightly run out when removed.

GEARBOX OIL LEVEL

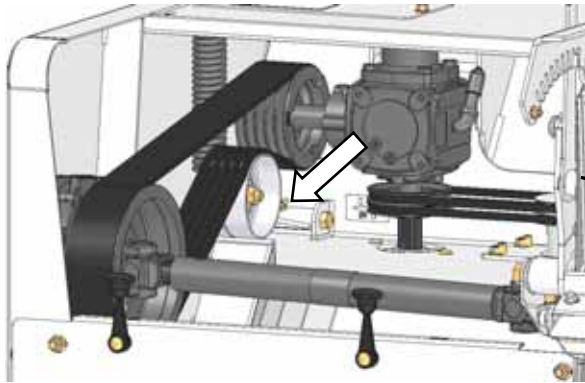

DRIVELINE UNIVERSALS (2 PLCS)



BELT TENSIONER PIVOT (1 PLC)

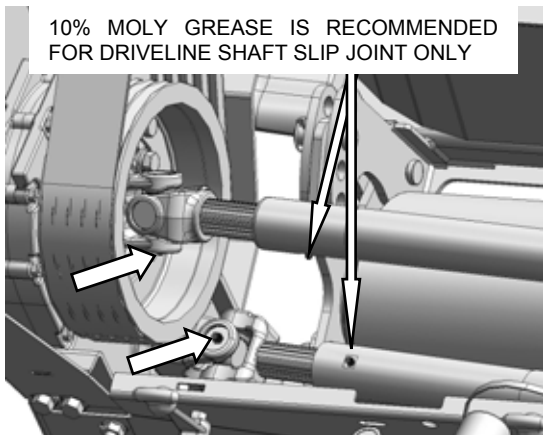
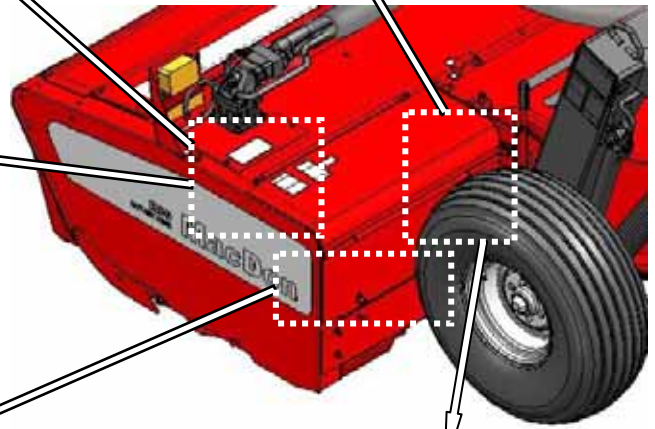

DRIVELINE UNIVERSALS (2 PLCS)  
DRIVELINE SHAFT (2 PLCS)



ROLL SHAFT BEARINGS (3 PLCS)

# UNLOADING AND ASSEMBLY

## LUBRICATION - CARRIER FRAME

High Temp. Extreme Pressure (EP2) Performance With 1% Max Molybdenum Disulphide (NLGI Grade 2).Lithium Base

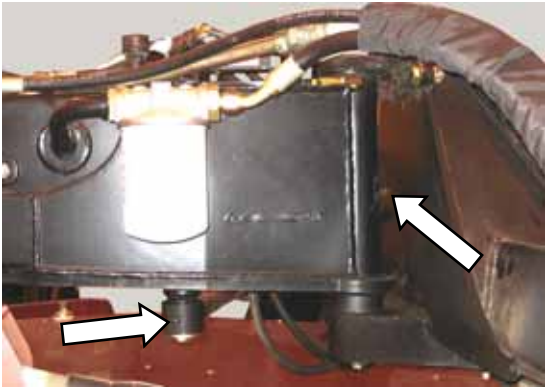
APT PIVOT & STEERING CYLINDER



WHEEL BEARING – BOTH SIDES

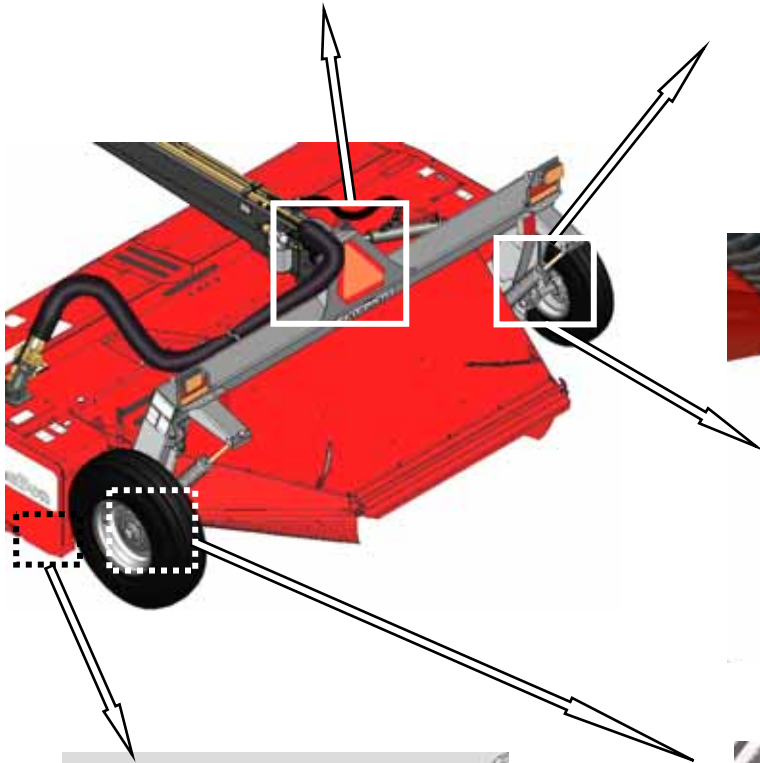

LIFT LINK 1PLC – BOTH SIDES

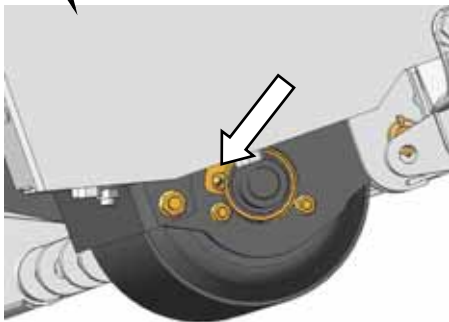

OPTIONAL GAUGE ROLL BEARINGS (2 PLCS)  
BOTH SIDES – 16 FT ONLY



CYLINDER PIVOT 1 PLC

## UNLOADING AND ASSEMBLY

### LUBRICATION - DRIVELINE

High Temp. Extreme Pressure  
(EP2) Performance With 1%  
Max Molybdenum Disulphide  
(NLGI Grade 2).Lithium Base

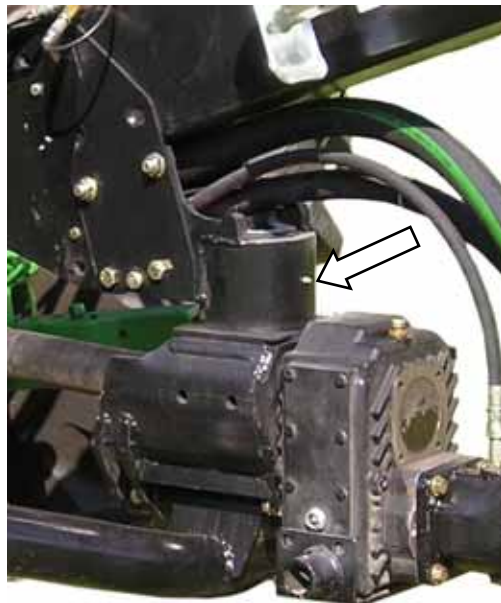

APT SWIVEL

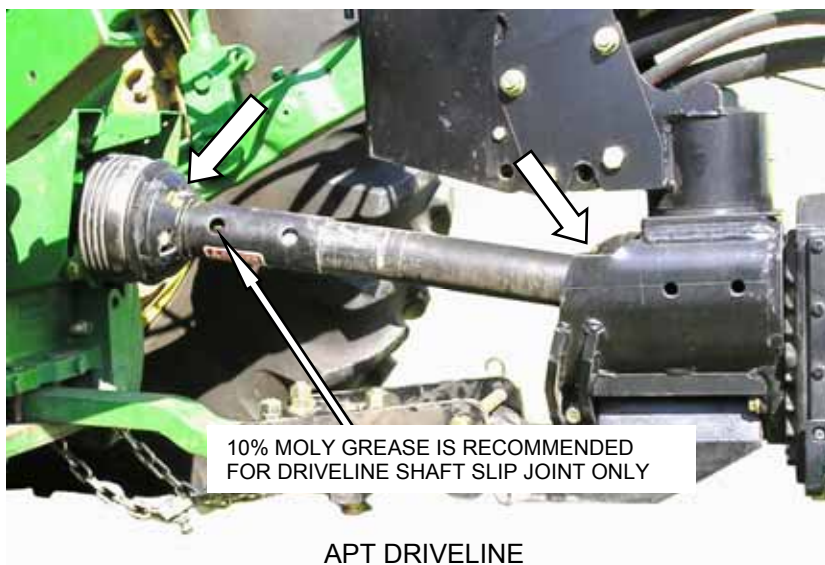

APT DRIVELINE

## PRE-DELIVERY CHECKS

### STEP 24. PERFORM PRE-DELIVERY CHECKS



#### WARNING

Stop tractor engine and remove key before making adjustments to machine. A child or even a pet could engage the drive.

#### IMPORTANT

To avoid machine damage, check that no shipping dunnage has fallen into cutterbar.

- Perform the final checks and adjustments as listed on the "Pre-Delivery Checklist" (yellow sheet attached to back of this instruction) to ensure the machine is field-ready. Refer to the pages for detailed instructions as indicated on the checklist.
- The completed checklist should be retained either by the operator or the dealer.

#### NOTE

*The majority of checks and adjustments are performed during the set-up procedures. The following additional inspections should be performed after the set-up is complete.*

### A. DRIVE BELTS

Drive belt tensions have been properly set at the factory and should not require any further adjustment. Check as follows:

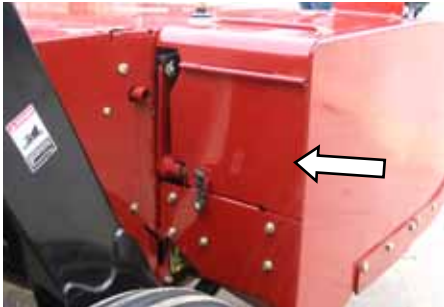

- Open RH drive shield.

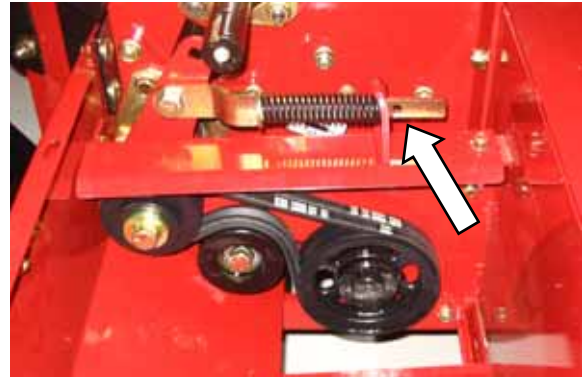

- Lifting roll drive belt tension is factory adjusted. Hole in tensioner member should be visible.

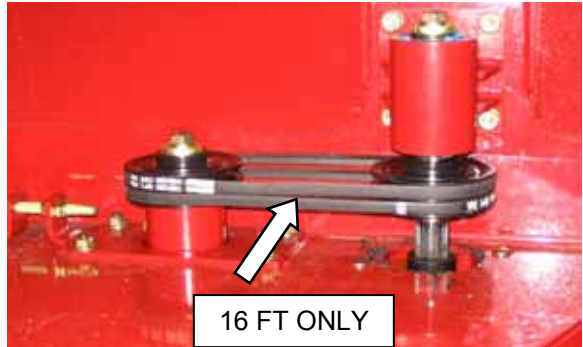

- Apply force of 51 lbf (22 N) to each deflector drive belt at mid-span. Deflection of each belt should be 0.12 in. (3 mm).



- Open LH drive shield.

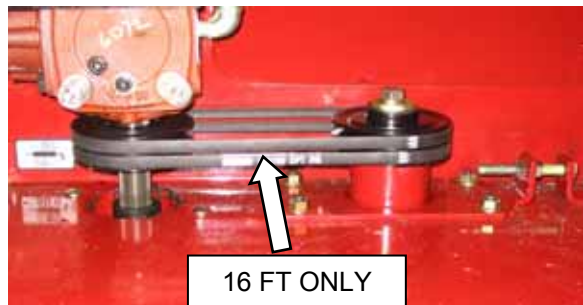

- Apply force of 51 lbf (22 N) to each deflector drive belt at mid-span. Deflection of each belt should be 0.12 in. (3 mm).

*(continued next page)*

## PRE-DELIVERY CHECKS

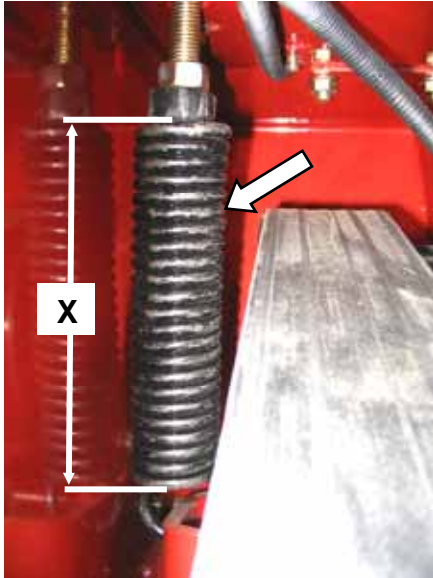

- f. Measure the length 'X' of the spring as shown. It should be within the dimensions in the following table.

NUMBER OF VISIBLE COILS	MEASUREMENT 'X'
23	7.75-8.15 inches (197-207 mm)
24	8.11-8.5 inches (206-216 mm)

## PRE-DELIVERY CHECKS

### B. CONDITIONER ROLLS



#### WARNING

Stop tractor engine and remove key before making adjustments to machine. A child or even a pet could engage the drive.

#### I. ROLL GAP

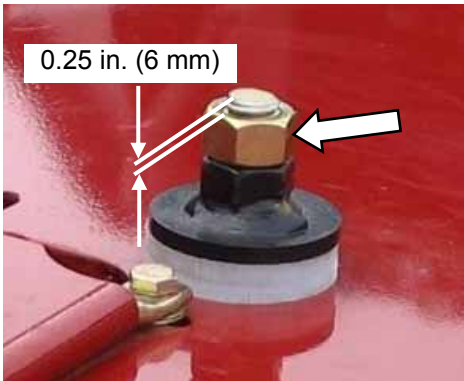
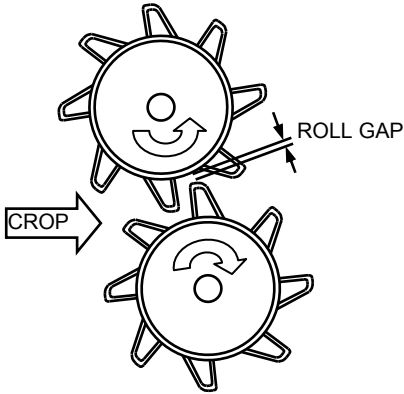

The amount of thread protruding through jam nut should equal roll gap. Factory setting should be 0.25 in. (6 mm) at each adjuster bolt.

#### II. ROLL TIMING

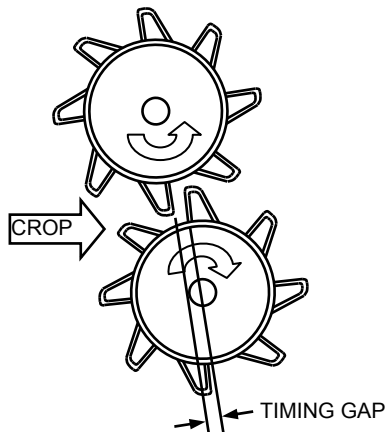

- a. Lower header to ground, shut down tractor and remove key.

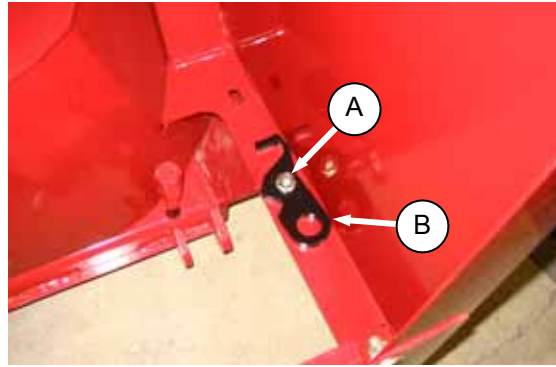

- b. Remove bolt (A) and nut, and remove gauge (B) from inside panel at RH end of header.

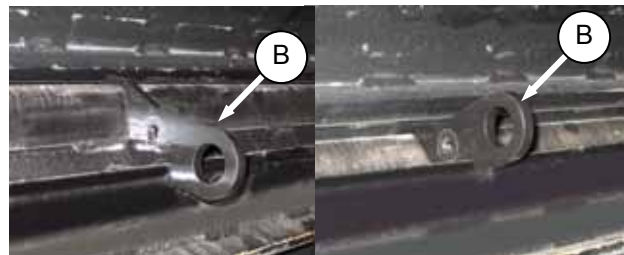

- c. From behind the header, locate gauge at center of rolls as shown and manually turn rolls to limits of gauge. Rolls will engage the gauge if timing is correct.

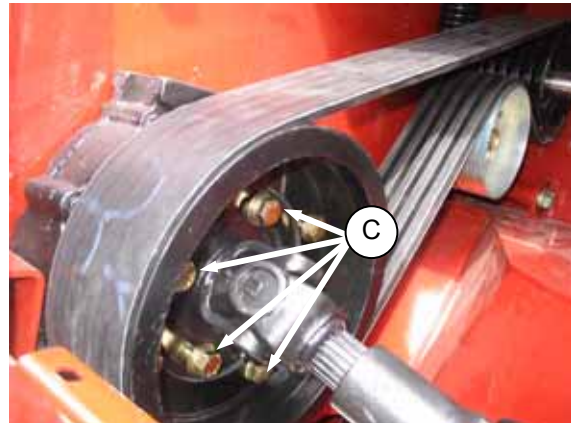

- d. Check timing flange bolts (C) are tight.
- e. Manually turn rolls in opposite direction to release gauge.
- f. Replace gauge (B) in header with bolt (A) and nut.

## PRE-DELIVERY CHECKS

### C. LIGHTS

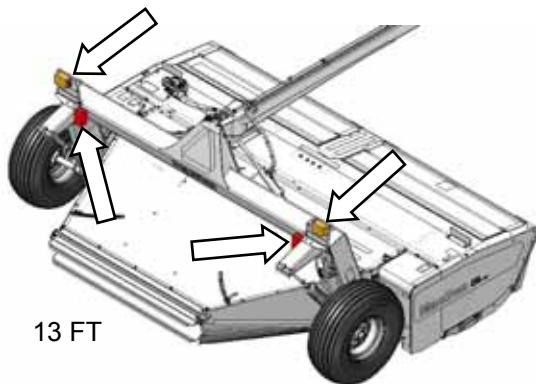
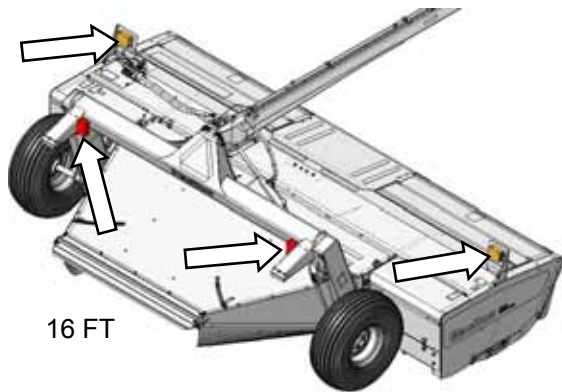

- The amber hazard lights are mounted on both ends of the header for the 16 ft mower-conditioner, and on the carrier frame for the 13 ft model. They are activated by switches in the tractor cab.
- The red running and brake lights are mounted on the carrier frame and are activated by a switch in the tractor cab and by applying the brakes on the tractor.
- Check light mountings for security and check lights for damage and for proper operation during run-up.

### D. MANUALS

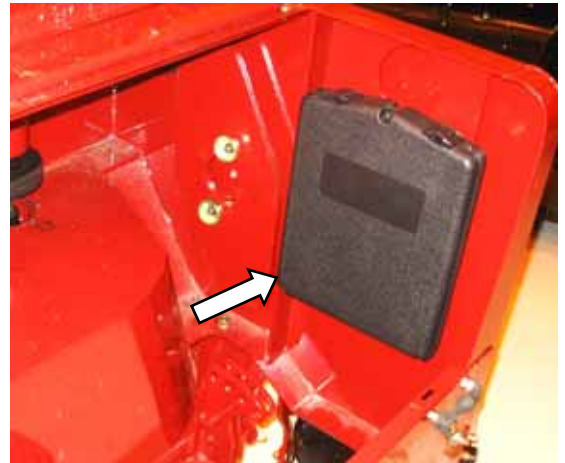

- The following manuals should be stored in the manual storage case inside the RH drive compartment:
  - R80 Rotary Disc Header PARTS CATALOG. Form #169054.
  - R80 Rotary Disc Pull-Type Windrower OPERATOR'S MANUAL. Form #169089.



- Close drive shields.

## PRE-DELIVERY CHECKS

### E. RUN-UP THE MOWER CONDITIONER



#### CAUTION

- Never start or move the machine until you are sure all bystanders have cleared the area.
- Clear the area of other persons, pets etc. Keep children away from machinery. Walk around the machine to be sure no one is under, on or close to it.
- Before investigating an unusual sound or attempting to correct a problem, shut off engine, engage parking brake and remove key.



#### DANGER

- Keep everyone several hundred feet away from your operation. Ensure bystanders are never in line with the front or rear of the machine. Stones or other foreign objects can be ejected from either end with force.



- Extreme care must be exercised to avoid injury from thrown objects. Do not, under any circumstances, operate the mower-conditioner when other people are in the vicinity. Stones and other objects can be thrown great distances by the rotating cutting blades.
- The cutterbar curtains are very important to reduce the potential for thrown objects. Always keep these curtains down when operating the mower-conditioner. Replace the curtains if they should become worn or damaged.

- a. Start tractor and run the mower conditioner slowly for 5 minutes, watching and listening FROM THE TRACTOR for binding, interfering parts, or unusual noises.



#### CAUTION

**Before investigating an unusual sound or attempting to correct a problem, shut off tractor, engage parking brake and remove key.**

- b. Run machine for 15 minutes and perform the run-up check as listed on the "Pre-Delivery Checklist" (yellow sheet attached to this instruction) to ensure the machine is field-ready.
- c. Retain the checklist and if desired, retain this instruction for future reference.

## NOTES

# MacDon™

**MacDon Industries Ltd.**

680 Moray Street  
Winnipeg, Manitoba  
Canada R3J 3S3  
t. (204) 885-5590  
f. (204) 832-7749

**MacDon Inc.**

10708 N. Pomona Avenue  
Kansas City, Missouri  
United States, 64153-1924  
t. (816) 891-7313  
f. (816) 891-7323

**MacDon Australia Pty. Ltd.**

A.C.N. 079 393 721  
P.O. Box 243  
Suite 3, 143 Main Street  
Greensborough, Victoria  
Australia 3088  
t. 03 9432 9982  
f. 03 9432 9972

**CUSTOMERS**

[www.macdon.com](http://www.macdon.com)

**DEALERS**

[www.macdondealers.com](http://www.macdondealers.com)

Trademarks of products are the marks of their  
respective manufacturers and/or distributors.

Printed in Canada

## R80 Rotary Disc Pull-Type Mower Conditioner Pre-Delivery Checklist

Perform these checks and adjustments prior to delivery to your customer. See the Unloading and Assembly Instructions for details. The completed checklist should be retained either by the operator or the dealer.



**CAUTION: Carefully follow the instructions given. Be alert for safety related messages which bring your attention to hazards and unsafe practices.**

**WARNING: Do not operate the machine with the drive shields open. High speed rotating components may throw debris and could result in death or serious injury.**

Header Serial Number: \_\_\_\_\_ APT Serial Number: \_\_\_\_\_

✓	<u>ITEM</u>	<u>PAGE</u>
	Check for shipping damage or missing parts. Be sure all shipping dunnage is removed.	--
	Check for loose hardware. Tighten to required torque.	4
	Check main drive belt tension.	42
	Check hourglass deflector drive belts tension (16 ft. only).	42
	Check lift roll drive belt tension.	42
	Check header angle to middle of adjustment range.	21
	Check header flotation. 95-105 lbf (426-471 N).	31
	Check tire pressure. 30 psi (207 kPa).	20
	Check wheel bolt torque. 120 ft-lbf (160 N-m).	20
	Check hydraulic oil level at sight glass on side of articulating power tongue.	17
	Check side forming shields evenly set to desired position. Ensure side shields are equal distance from centre line of tongue pivot.	32
	Check rear fluffer deflector about half way down.	32
	Check crop deflector set about half way.	32
	Check gauge rollers/skid shoes evenly set (16 ft. only).	10
	Check bevel gearbox lube level.	38-39
	Grease all bearings and drivelines.	37-41
	Check conditioner roll gap and timing.	44
	Check roll intermesh hardware is securely tightened.	44
	Check cutterbar curtains hanging properly.	14
	Check hydraulic hose and wiring harness routing.	--
	Check cutterbar area carefully for loose parts and hardware on the cutterbar. <b>WARNING: These objects can be ejected with considerable force when the machine is started and may result in serious injury or machine damage.</b>	--
	RUN-UP PROCEDURE	46
	Check hydraulic hose and wiring harness routing for clearance when raising or lowering header.	--
	Check tail lights and hazard lights are functional.	45
	POST RUN-UP CHECKS. STOP ENGINE.	--
	Check belt drives for idler alignment and heated bearings.	42
	Check for hydraulic leaks.	--
	Check header manuals in header storage case.	45

Date Checked: \_\_\_\_\_

Checked by: \_\_\_\_\_